

CONTACTOR RANGE

Type **SEC**

RAIL VEHICLES / FIXED INSTALLATION



GENERAL INFORMATION

The **SEC** contactor is a high duty class component, designed to withstand the most severe applications in terms of environment and required performances for rail mobility or fixed installations. Combining high electrical and mechanical endurance, efficient low

current bi-directional blow-out device, and a smart control unit making the SEC operation independent from both ambient temperature and control voltage, the **SEC** is a unique contactor to be used almost regardless of the service conditions.

APPLICATIONS, TYPICAL EXAMPLES

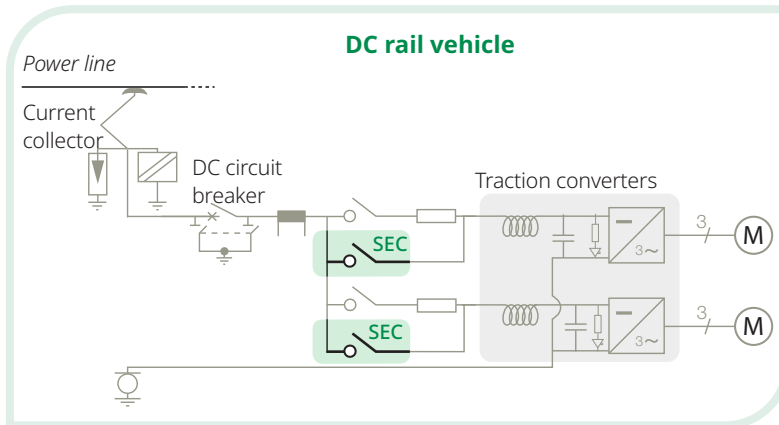

LINE CONTACTORS FOR DC VEHICLES

Locomotives, trains, EMUs, tramways / Light Rail Vehicles

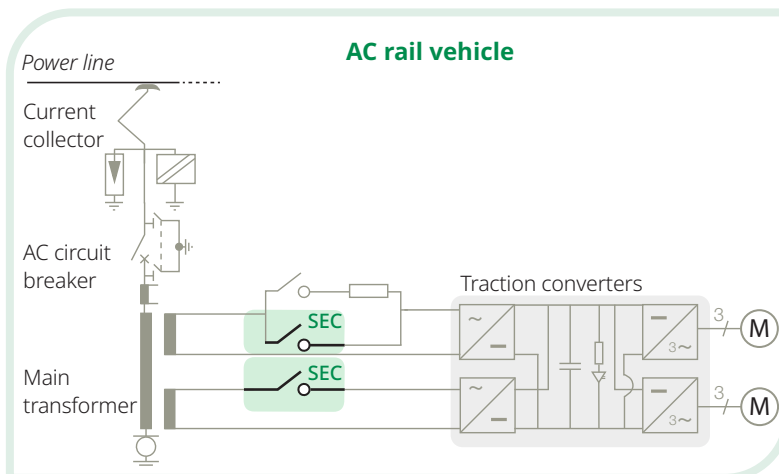

SEPARATION/LINE CONTACTORS FOR AC VEHICLES

Locomotives, trains and EMUs

MAIN FEATURES

- Rated operational voltage 900 V to 4,000 V (DC and AC)
- Rated free air thermal current 1,000 A or 1,300 A
- High insulation level (overvoltage category OV3)
- Reference standards: IEC 60077-1 /-2 , IEC 61373, EN 50121-3-2, EN 45545, EN 50657.

MAIN BENEFITS

- ✓ Operational frequency category C3 for 1,000 A and C2 for 1,300 A with a minimum mechanical durability of 2,000,000 operations
- ✓ Efficient blow-out circuit for low current interruptions
- ✓ Reduced power consumption thanks to a coil controller that controls the closing and opening operations
- ✓ Closing and opening performances independant from both control voltage level and ambient temperature
- ✓ Horizontal or vertical mounting
- ✓ Double pair of main contacts allowing a longer life time
- ✓ Low maintenance requirements and easy access to the main contacts for replacement.

CONTACTOR CONFIGURATIONS

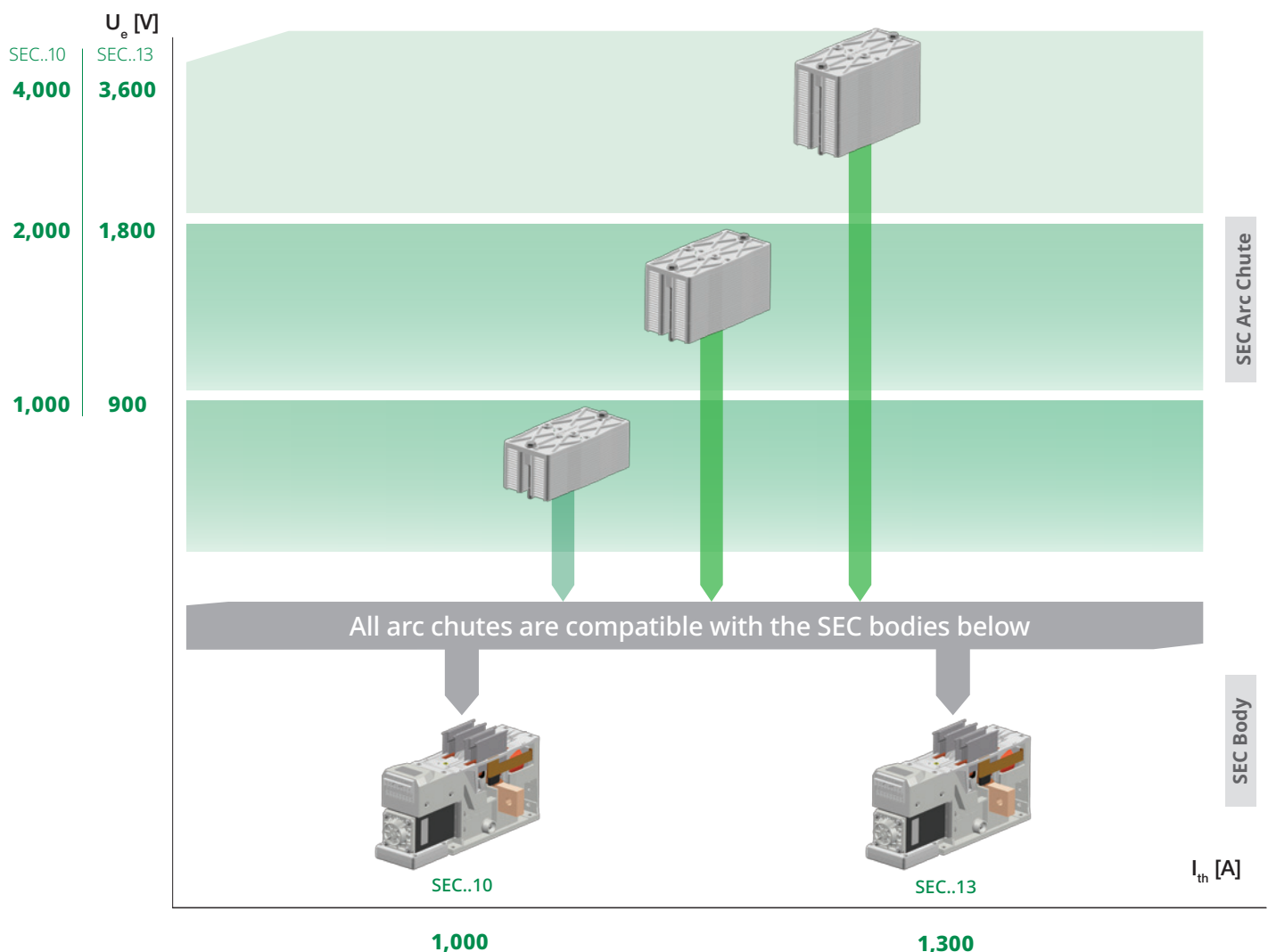

DATA FOR PRODUCT SELECTION

Symbol	Unit	SEC 10.10	SEC 20.10	SEC 40.10	SEC 09.13	SEC 18.13	SEC 36.13
MAIN HIGH VOLTAGE CIRCUIT							
Component category		A2					
Type of main contact		Normally Open					
Number of poles		1 pole					
Rated operational voltage	U_{Ni} [V _{DC} /V _{AC}]	1,000	2,000	4,000	900	1,800	3,600
Rated insulation voltage	U_{Nm} [V]	2,000	2,000	4,000	2,000	2,000	4,000
Conventional free air thermal current ⁽¹⁾	I_{th} [A]	1,000			1,300		
Rated operational current/operational frequency		1,000 / C3			1,000 / C3		
- DC voltage or AC voltage (16.7, 25 & 50/60 Hz)	I_r [A]				1,300 / C2		
Rated short-time withstand current	$I_{cw/t}$ [kA]/[ms]	10/100					
Peak short-time withstand current	\hat{I}_{cw} [kA]	10					
Maximum breaking capacity							
- DC current, $\tau = 15$ ms	I_{bc} [A]	4,000	3,000	2,500	4,000	3,000	2,000
- AC current, $\cos \Phi = 0.8$ (16.7, 25 & 50/60 Hz)	I_{bc} [A]	4,000	3,000	2,500	4,000	3,000	2,000
Maximum making capacity	I_{mc} [A]	4,000	3,000	2,500	4,000	3,000	2,000
Rated power-frequency withstand voltage (50 Hz/1 min)							
- Between main contacts (open)	U_{Ni} [kV]	4.7		7.9	4.7		7.9
- Main circuit (closed) to earth	U_{Ni} [kV]	6.0		10	6.0		10
Breaking overvoltage	\hat{U}_c [V]	≤ 2,000	≤ 3,500	≤ 7,000	≤ 2,000	≤ 3,500	≤ 7,000
Overvoltage category		OV3	OV3	OV3	OV3	OV3	OV3

⁽¹⁾ At $T_{amb} = +40^\circ\text{C}$ and tested with size of high voltage cable connections per terminal: 2x240mm² for SEC ...10 and 3x240 mm² for SEC ...13.

LOW VOLTAGE CIRCUITS

Control circuit

Nominal supply voltage	U_n [V _{DC}]	[24 - 36] or [48 - 110]					
Control voltage	U_{EF} [V _{DC}]	24 to 110					
Range of voltage		[0.7 - 1.25] U_n					
Nominal closing power ⁽³⁾	P_c [W]	≤ 60 ⁽²⁾					
Nominal holding power ⁽³⁾	P_m [W]	≤ 4					
Input control current ⁽³⁾	[mA]	10 (24 V _{DC}) to 2 (110 V _{DC})					
Mechanical closing time ⁽³⁾	t_{cc} [ms]	100	100	130	100	100	130
Mechanical opening time ⁽³⁾⁽⁴⁾	t_{co} [ms]	50					

⁽²⁾ For a duration ≤ 0.5 s. • ⁽³⁾ At U_n and $T_{amb} = +20^\circ\text{C}$. • ⁽⁴⁾ For direct control mode opening +10 ms additional time, for closing +60 ms additional time. •

Auxiliary contacts

Type of contacts		Potential free (PF)					
Rated voltage	[V _{DC}]	24 to 220					
Conventional thermal current	I_{th} [A]	10					
Utilization categories according to EN60947							
- AC-15 230 V _{AC}		1.0 A					
- DC-13 110 V _{DC}		0.5 A					
Minimum let-through current at 24 V _{DC} ⁽⁵⁾	[mA]	≥ 10 (silver contacts) or 4 ≤ I < 10 (gold contacts)					

⁽⁵⁾ For a dry and clean environment.

Low voltage interface

Control circuits & Auxiliary switches		Terminal block or AMP 18 pins connector					
---------------------------------------	--	---	--	--	--	--	--

Low voltage interface

Rated power-frequency withstand voltage (50 Hz / 1 min)							
- LV circuit to earth	U_a [kV]	1.5					

OPERATING CONDITIONS

Installation		Indoor					
Altitude	[m]	≤ 2,000					
Working ambient temperature	T_{amb} [°C]	-40 to +70					
Humidity		95% at +40°C					
Pollution degree		PD3					
Protection Index (low voltage circuit)	N Cycles	2 Millions					

PRODUCT INTEGRATION

MAIN DIMENSIONS

HV connections	M12 screws
Earth connections	M6 screws
LV Connections	M3 screws terminal block or AMP connector (option)
Fixing points	M8 Screws

Dimensions without tolerances are indicative. All dimensions are in mm. The maximum allowed flatness deviation of the support frame is 0.5 mm.

High voltage lateral connections

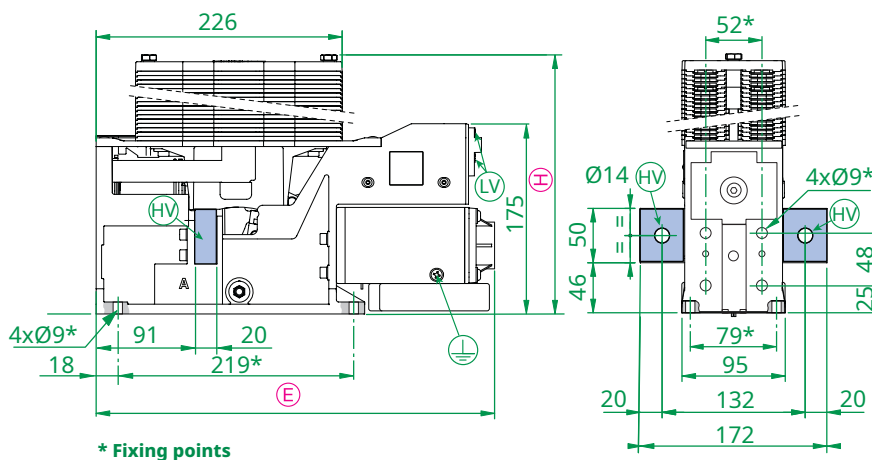

* Fixing points

SEC..10/SEC..13

Horizontal/Vertical installation



Dimensions [mm]	SEC10.10 SEC09.13	SEC20.10 SEC18.13	SEC40.10 SEC36.13
Ⓔ	366	366	371
Ⓕ	239	275	375

INSULATION DISTANCES AND WEIGHTS

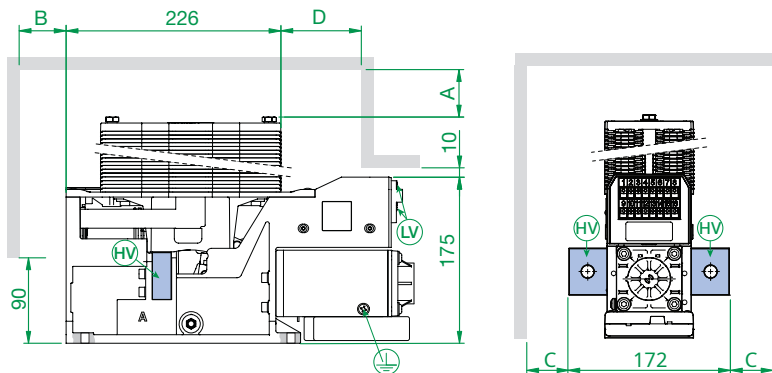

SEC contactors have been homologated according to IEC 60077-2 with the following insulation distances.

	Insulating distance [mm]				Weight: ± 1 kg
	To insulating wall				
	A	B ⁽³⁾	C	D	
SEC10.10 SEC09.13	30 ⁽¹⁾ /50 ⁽²⁾	50 ⁽¹⁾ /100 ⁽²⁾	20 ⁽¹⁾ /30 ⁽²⁾	50 ⁽¹⁾ /100 ⁽²⁾	11
SEC20.10 SEC18.13	30 ⁽¹⁾ /50 ⁽²⁾	50 ⁽¹⁾ /100 ⁽²⁾	20 ⁽¹⁾ /50 ⁽²⁾	50 ⁽¹⁾ /100 ⁽²⁾	12.5
SEC40.10 SEC36.13	30 ⁽¹⁾ /50 ⁽²⁾	100 ⁽¹⁾ /200 ⁽²⁾	50 ⁽¹⁾ /80 ⁽²⁾	100 ⁽¹⁾ /200 ⁽²⁾	16

⁽¹⁾ Clearance against insulating wall.

⁽²⁾ Clearance against earth.

⁽³⁾ For breaking current ≤ 2kA (≤ 1kA for SEC40.10 and SEC36.13). For higher breaking conditions please contact Sécheron.

LOW VOLTAGE CONTROL DIAGRAM

Low voltage control mode

The two control modes that can be used to control the SEC are represented hereunder:

- Indirect mode
- Direct mode

Required data for k0 and k1 control relays :

	Nominal supply voltage $U_n [V_{DC}]$	$\hat{I}_{pl} [A]$	$\hat{I}_h [A]$	$I_{sb} [mA]$	$I_{pk} [mA]$
Required data K_0 relays ⁽¹⁾	24-36	4.5	0.85	≤ 30	≤ 500
	48-110	2.5	0.45		

	Nominal control voltage $U_{EF} [V_{DC}]$	$I [mA]$
Required data K_1 relays ⁽¹⁾	24	~ 10
	110	~ 2

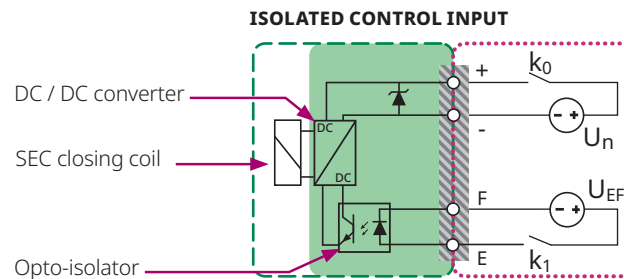
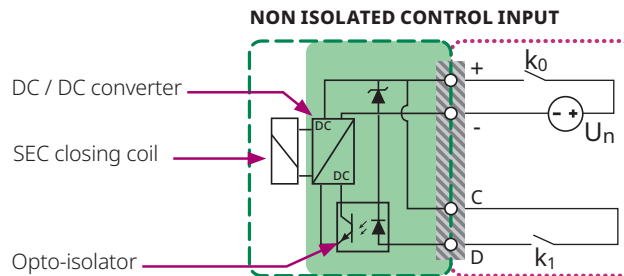

- - - Sécheron's scope
- Customer's scope
- Low voltage interface
- Coil controller

- U_n : DC power supply
- U_{EF} : Control voltage ⁽¹⁾
- k_0 : Supply relay
- k_1 : Control relay

INDIRECT MODE

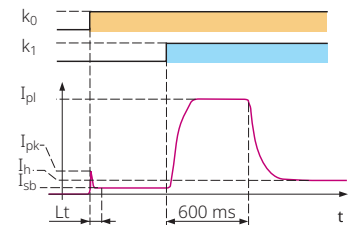

Notes:

Isolated or non isolated control mode is to be determined when ordering. Please refer to codification page 12.

In case the customer needs to have the full electrical compatibility with former coil controller version, the "Non isolated control input" version must be ordered.

⁽¹⁾ Control voltage (U_{EF}) can be different from supply voltage (U_n).

DIRECT MODE

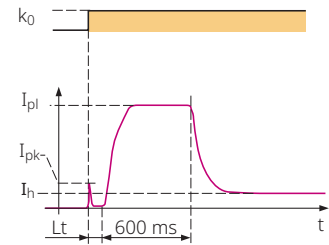
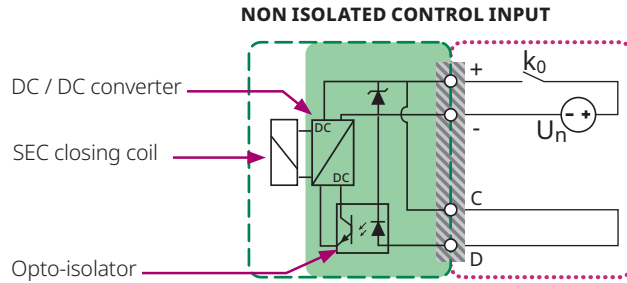

Wiring diagram with 2a + 2b auxiliary switches (Configuration 1) - Standard

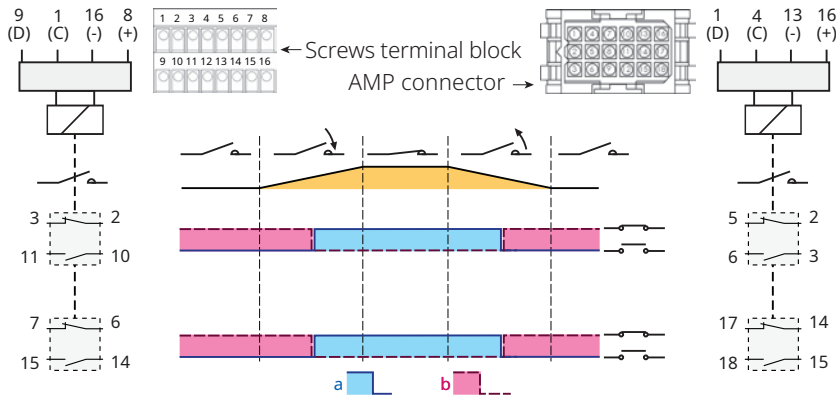

Legend of the schemes:

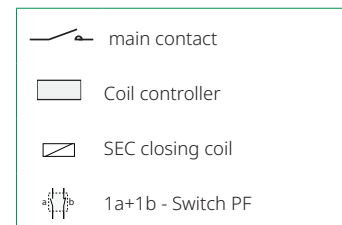

Wiring diagram with 2a + 2b auxiliary switches (Configuration 2) - Option

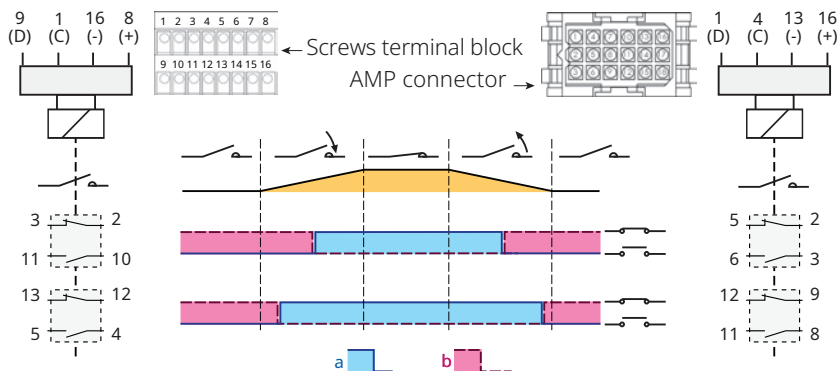

Notes:

Difference between configuration 1 & 2 relates to the switching offset time between auxiliary switches.

Wiring diagram with 3a + 3b auxiliary switches
(Configuration 3) - Option

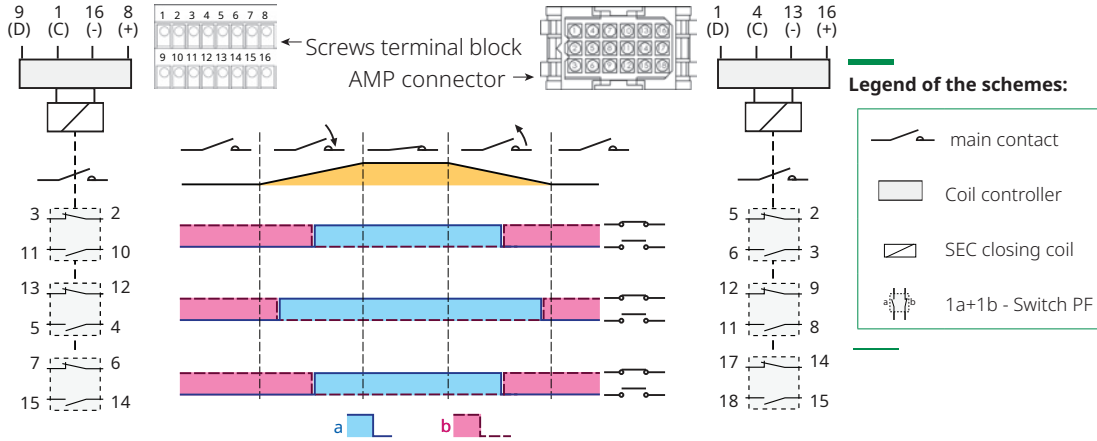

OPTIONS (SUBJECT TO ADDITIONAL COSTS)

LOW VOLTAGE AMP CONNECTOR

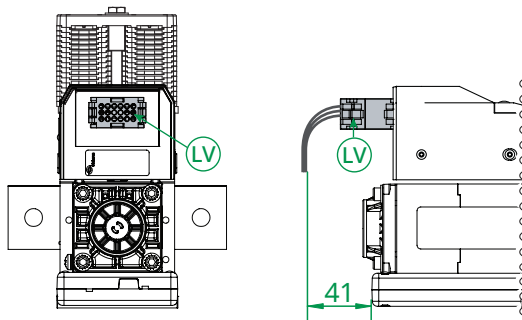

The low voltage AMP mobile connector can be ordered separately.

Mobile connectors	
Type	Secheron's number
AMP connector 18 pins for 0.5 mm ²	SG201013R1
AMP connector 18 pins for 1.5 mm ²	SG201013R2

LOW VOLTAGE AMP CONNECTOR

HV connections	M12 screws
Earth connections	M6 screws
LV Connections	M3 screws terminal block or AMP connector (option)
Fixing points	M8 Screws

Dimensions, Insulation distances and weights

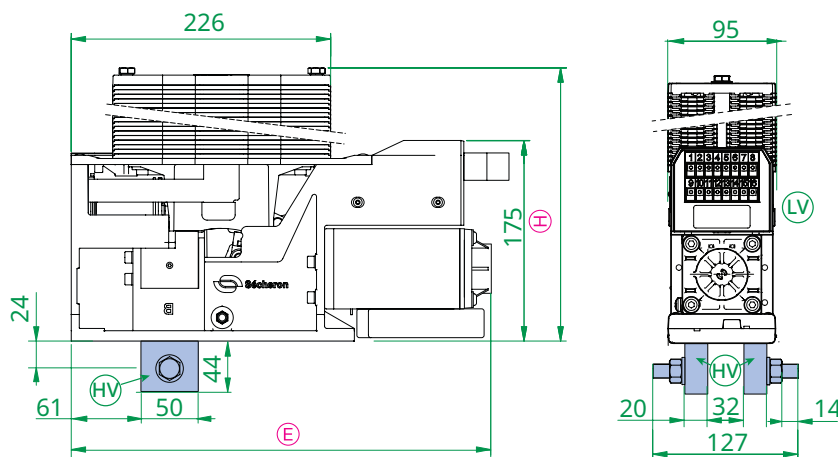

Dimensions [mm]	SEC10.10 SEC09.13	SEC20.10 SEC18.13	SEC40.10 SEC36.13
(E)	366	366	371
(H)	239	275	375
Weight	12 kg	13.5 kg	17 kg

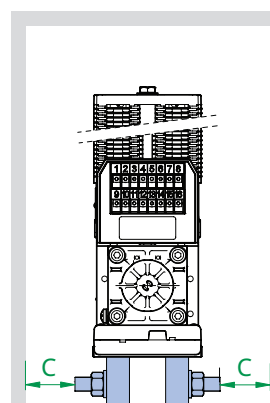
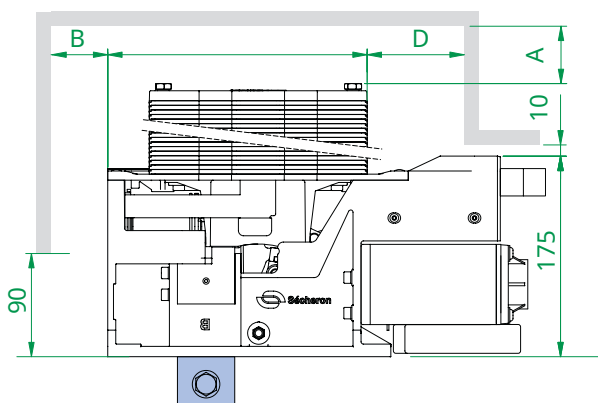

Dimensions [mm]	SEC10.10 SEC09.13	SEC20.10 SEC18.13	SEC40.10 SEC36.13
A	30 ⁽¹⁾ /50 ⁽²⁾	30 ⁽¹⁾ /50 ⁽²⁾	30 ⁽¹⁾ /50 ⁽²⁾
B ⁽³⁾	50 ⁽¹⁾ /100 ⁽²⁾	50 ⁽¹⁾ /100 ⁽²⁾	100 ⁽¹⁾ /200 ⁽²⁾
C	20 ⁽¹⁾ /30 ⁽²⁾	20 ⁽¹⁾ /50 ⁽²⁾	50 ⁽¹⁾ /80 ⁽²⁾
D	50 ⁽¹⁾ /100 ⁽²⁾	50 ⁽¹⁾ /100 ⁽²⁾	100 ⁽¹⁾ /200 ⁽²⁾
Weight	12 kg	13.5 kg	17 kg

⁽¹⁾ Clearance against insulating wall.

⁽²⁾ Clearance against earth.

⁽³⁾ For breaking current $\leq 2\text{kA}$
($\leq 1\text{kA}$ for SEC40.10 and SEC36.13).
For higher breaking conditions please
contact Sécheron.

SECHERON CONTACTORS RANGE

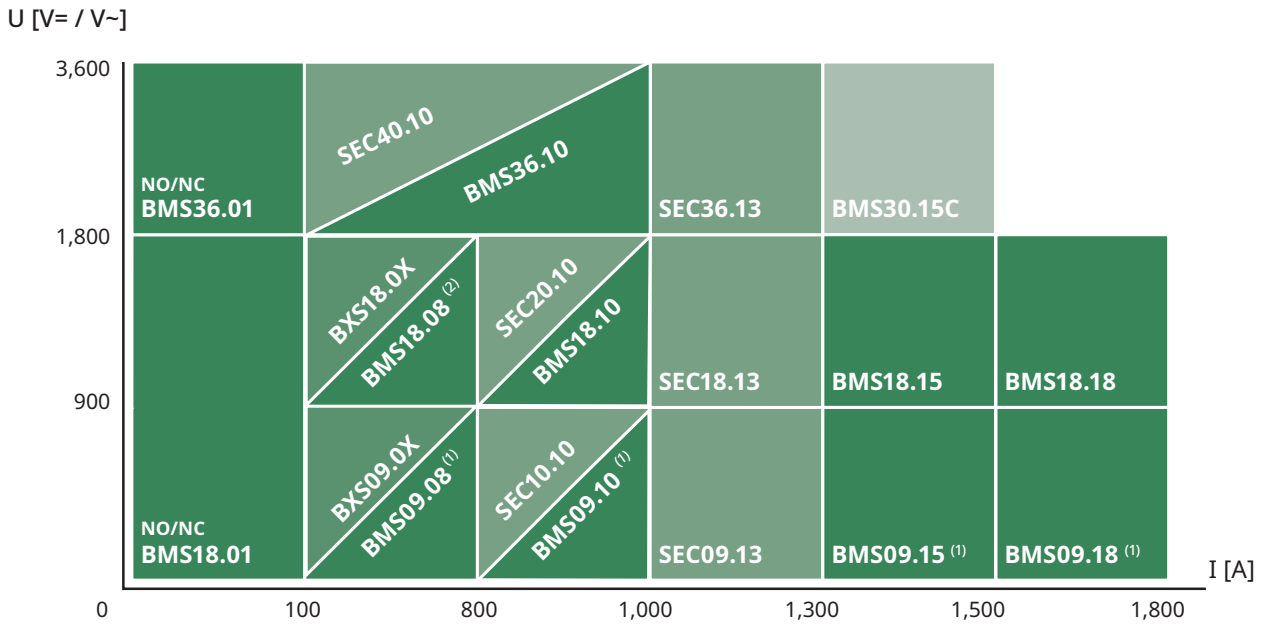

BMS15.002 and HS contactors are still available on request for delivery for repeat order or as spares.

⁽¹⁾ BMS09... can be used for rated voltages up to 2,000 V_{AC}

⁽²⁾ A specific version of BMS18.08 can also be used for rated voltage up to 4,000 V_{AC}

AT A GLANCE

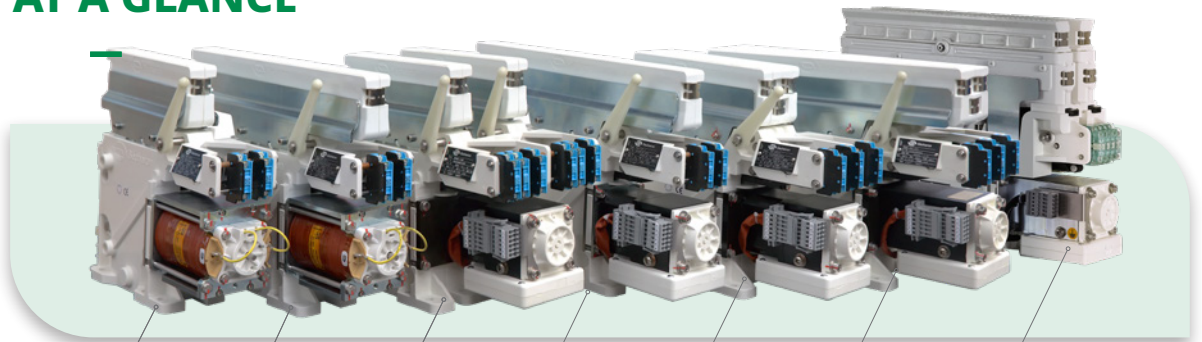

BMS 09.08

1 pole
Arc chute
Type A

BMS 18.08

1 pole
Arc chute
Type A

BMS 09.08

2 poles
Arc chute
Type A

BMS 18.10

1 pole
Arc chute
Type A

BMS 09.15

1 pole
Arc chute
Type A

BMS 18.18

1 pole
Arc chute
Type A

BMS 36.10

1 pole

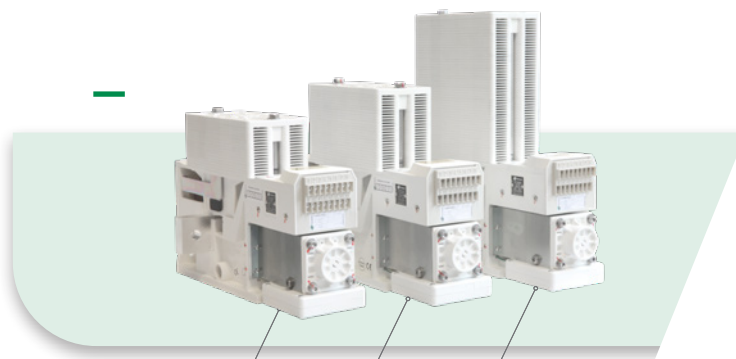

SEC10.10/
SEC09.13

SEC20.10/
SEC18.13

SEC40.10/
SEC36.13

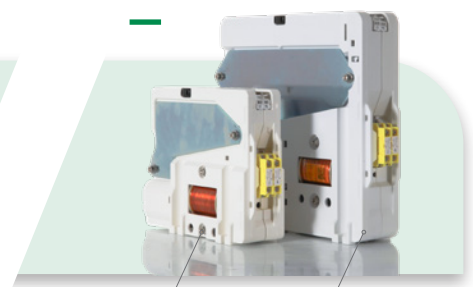

BMS18.01

BMS36.01

BROCHURE REFERENCE FOR OTHER SÉCHERON'S CONTACTORS



BMS..08/BMS..10 Type

ROLLING STOCK

(Line/separation contactors, ...).

FIXED INSTALLATION

(depot feeder contactor...).



BMS..08 3-pole Type

ROLLING STOCK

(Line/separation contactors, ...).

FIXED INSTALLATION

(depot feeder contactor, ...).



BMS..15/BMS..18 Type

ROLLING STOCK

(Line/separation contactors, ...).

FIXED INSTALLATION

(depot feeder contactor...).



SEC Type

ROLLING STOCK

(Line/separation contactors, PM motor,...).

FIXED INSTALLATION

(depot feeder contactor, ...).



BMS15.002 Type

ROLLING STOCK

(Pre-charging, Heating, HVAC, ...).

FIXED INSTALLATION

(Line testing, ...).



BMS30.15C Type

ROLLING STOCK

(Line/separation contactors, ...).

FIXED INSTALLATION

(depot feeder contactor, ...).



HS Type

ROLLING STOCK

(Pre-charging, Heating, HVAC, ...).

FIXED INSTALLATION

(Line testing, ...).

DESIGNATION CODE FOR ORDERING

- Be sure to establish the designation code from the latest version of our brochure by downloading it from the website: www.secheron.com.
- Be careful to write down the complete alphanumeric designation code with 12 characters when placing your order.
- For technical reasons some variants and options indicated in the designation code might not be combined, therefore validate your configuration with Sécheron before ordering.
- For other configurations not described in the brochure, please contact Sécheron.

Example of customer's choice:	SEC	10	10	01	S	1	Ø
Line:	10	11	12	13	14	15	16

- The bold characters of the designation code define the device type.

DESIGNATION CODE

Line	Description	Designation	Standard	Options	Customer's choice
10	Product type BMS	SEC	SEC		SEC
11	Rated operational voltage	1,000 V 2,000 V 4,000 V 900 V 1,800 V 3,600 V	10 20 40 09 18 36		
12	Rated conventional free air thermal current ⁽¹⁾	(1,000; 2,000 and 4,000 V) 1,000 A (900; 1,800 and 3,600 V) 1,300 A	10 13		
13	High voltage connections	Lateral Bottom with screws	01	02	
14	Nominal supply voltage - control mode	24 to 36 V _{dc} - Isolated 48 to 110 V _{dc} - Isolated 24 to 36 V _{dc} - Non Isolated 48 to 110 V _{dc} - Non Isolated	P S	L M	
15	Auxiliary contacts	2a + 2b - (switch PF) - silver type - Configuration 1 2a + 2b - (switch PF) - gold type - Configuration 1 2a + 2b - (switch PF) - silver type - Configuration 2 2a + 2b - (switch PF) - gold type - Configuration 2 3a + 3b - (switch PF) - silver type - Configuration 3 3a + 3b - (switch PF) - gold type - Configuration 3	1	4 2 6 3 5	
16	Low voltage interface	Screw terminal block AMP 18 pins connector	Ø	1	

⁽¹⁾ At Tamb = +40°C

The low voltage connector must be ordered separately (refer to above description):

- None
- AMP connector 18 pins of 0.5 mm² SG201013R1
- AMP connector 18 pins of 1.5 mm² SG201013R2



Sécheron SA
Rue du Pré-Bouvier 25
1242 Satigny - Geneva
CH-Switzerland

www.secheron.com
Tel: +41 22 739 41 11
Fax: +41 22 739 48 11
ess@secheron.com