

CONTACTORS

Type **BMS09.08 / BMS18.08**
BMS09.10 / BMS18.10

RAIL VEHICLES / FIXED INSTALLATION



GENERAL INFORMATION

The **BMS** contactor, with more than one hundred and fifty thousands units in operation worldwide, is a contactor valued by the car builders and operators of electric traction vehicles for its strong performance level and its extremely high reliability. Taking advantages of its recognized features and design, Sécheron has modernized the BMS to make a product platform particularly well adapted to actual requirements and standards. With its high modularity, the **BMS** offers variants and options that enable our customers to find

the most appropriate version to fit their application either as a stand-alone contactor, or delivered coupled with a Sécheron dedicated charging contactor type **PCC18**. Power contactor modules, convenient to order and easy to install, are a frequent wish of our customers. Sécheron brings the best solution with “plug & play” units gathering line and charging contactors, but also current measurement and customised high voltage and low voltage interfaces.

APPLICATIONS, TYPICAL EXAMPLES

- Line contactors for DC vehicles.

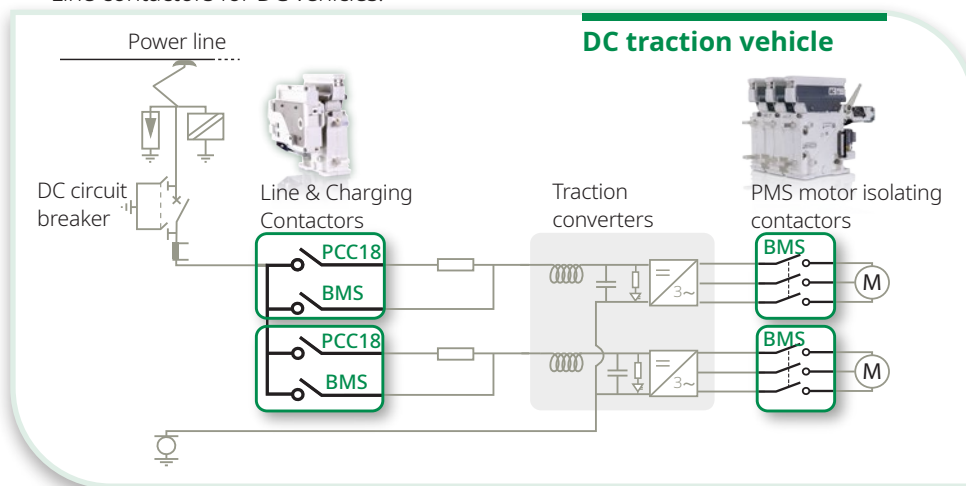

- Separation/line contactors for AC vehicles.

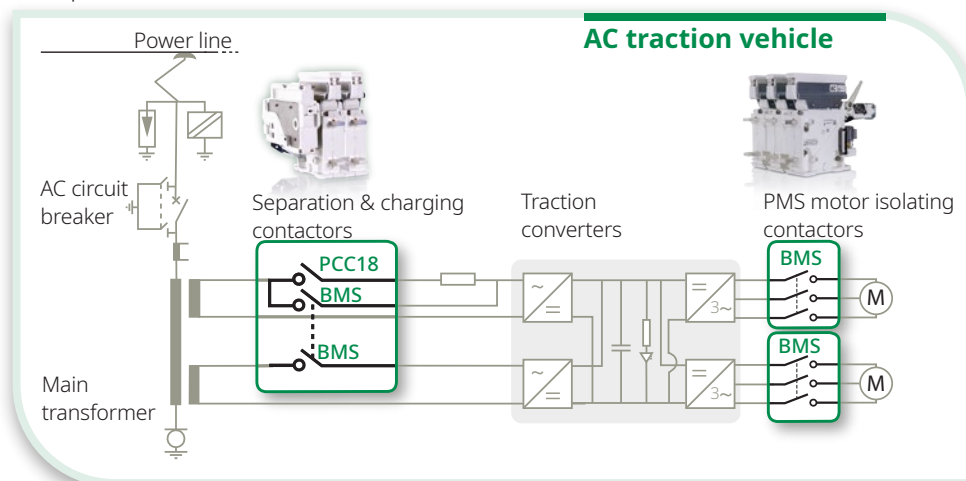

- Other applications for locomotives, trains, EMUs, tramways/light rail vehicles, including dual mode rail vehicles with battery.
- Battery charging contactors for e-Bus or dual mode Bus.
- Contactors for DC traction power substations and other industrial fields.

MAIN FEATURES

- Normally open and bi-directional contactor.
- Rated voltage 900 V_{DC} / 1,800 V_{DC} / 2,000 V_{AC}.
- Conventional free air thermal current 800 A or 1'000 A.
- Available in 1, 2 or 3 poles (BMS..08).
- Low voltage control coil protection against surges.
- Suitable for ambient temperature from -40°C to +70°C.
- Reference standards: EN/IEC 60077-1/-2, EN/IEC 61373, EN 45545, EN 50657.

MAIN BENEFITS

- ✓ Very compact size and extremely low weight.
- ✓ No critical current.
- ✓ Different arc chutes matching installation space and operational performance requirements.
- ✓ Small arc chute also valid for 2,000 VAC.
- ✓ High mechanical and electrical durability.
- ✓ Horizontal or vertical mounting to match vehicle's installation constraints.
- ✓ High modularity of the range.
- ✓ Possible integration of optional charging contactor type PCC18 directly on BMS line contactor.
- ✓ Low maintenance requirements with easy access to the main contacts for replacement.
- ✓ Worldwide service proven.

CONTACTOR CONFIGURATIONS

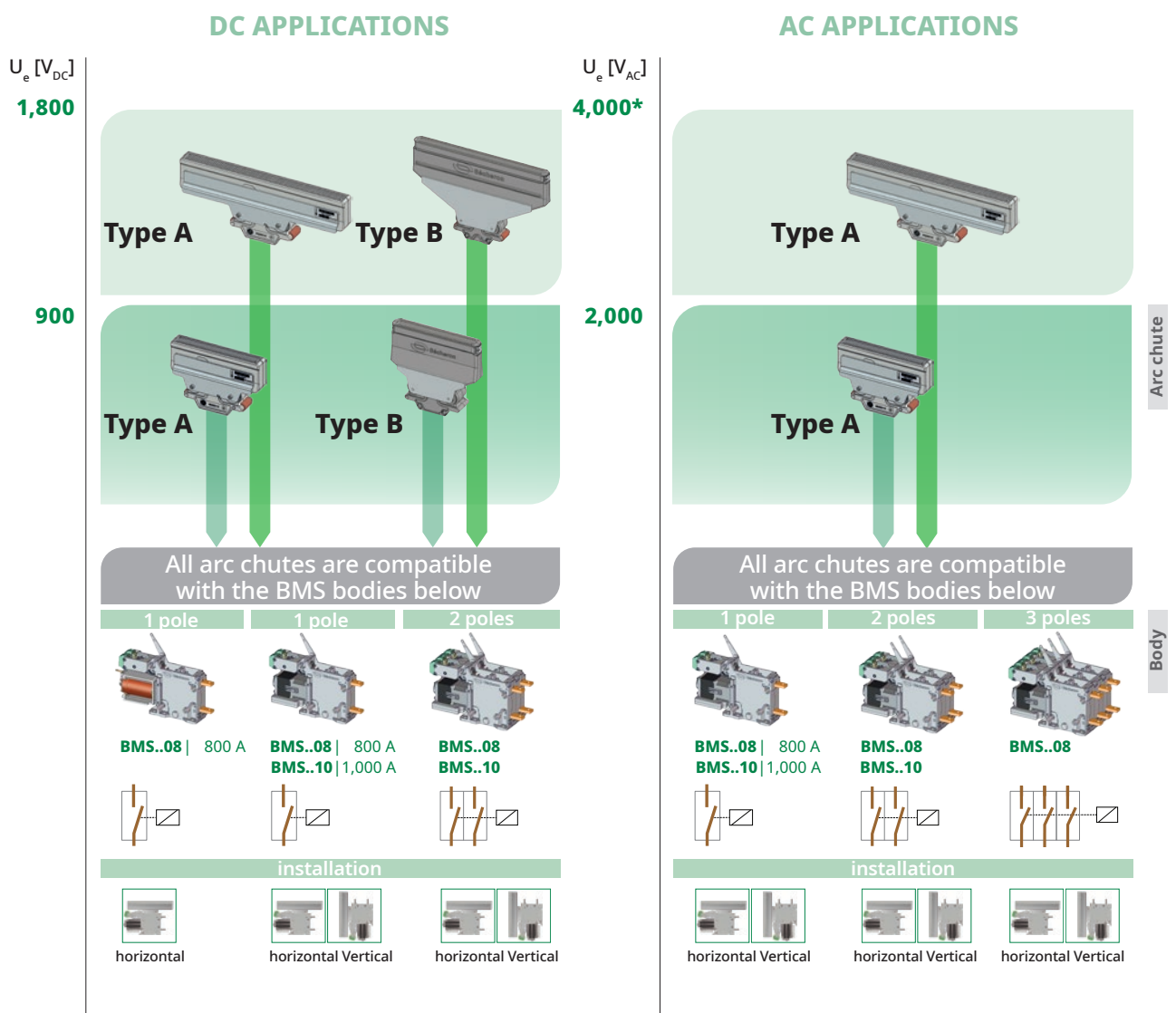

* for applications with Permanent Magnets Synchronous Motors and frequency up to 400 Hz. For detailed information refer to dedicated brochure SA003724.

DATA FOR PRODUCT SELECTION

Symbol	Unit	BMS 09.08	BMS 09.10	BMS 18.08	BMS 18.10	PCC18
MAIN HIGH VOLTAGE CIRCUIT						
Pole quantity		1, 2, 3 (AC only)	1, 2	1, 2, 3 (AC only)	1, 2	1
Component category		A2				
Type of main contact		Normally Open				
Rated operational voltage						
- DC voltage	U_e / U_r [V]	900		1,800		1,800
- AC voltage (16.7, 25, 50/60, ...400 Hz ⁽¹⁾)	[V]	2,000		-		2,000
Rated insulation voltage	U_i / U_{Nm} [V _{DC}]	2,300		2,300		2,300
	[V _{AC}]	2,300		-		2,300
Conventional free air thermal current ⁽²⁾	I_{th} [A]					
- DC voltage & AC voltage (16.7, 25, 50/60 Hz)		800	1,000	800	1,000	N.A.
- AC voltage (250 Hz)		600	-	600	-	N.A.
- AC voltage (400 Hz)		400	-	400	-	N.A.
Rated operational current/operational frequency						
- Horizontal mounting: DC	I_e / I_r [A]	800 / C1 ⁽³⁾ (C2 ⁽⁴⁾)		800 / C1 ⁽³⁾		100
DC	I_e / I_r [A]	500 / C2 ⁽³⁾		500 / C2 ⁽³⁾		-
AC	I_e / I_r [A]	800 / C2 ⁽³⁾		-		100
- Vertical mounting: DC	I_e / I_r [A]	500 / C2 ⁽³⁾ - 800 / C1 ⁽³⁾ (C2 ⁽⁴⁾)		800 / C1 ⁽³⁾ (4) - 500 / C2 ⁽³⁾ (4)		N.A.
AC	I_e / I_r [A]	800 / C1		-		N.A.
Maximum breaking capacity						
- DC current, $\tau = 15$ ms	I_{bc} [A]	3,200 ⁽³⁾ (6,000 ⁽⁴⁾)		2,300 ⁽³⁾ (6,000 ⁽⁴⁾)		200
- AC current, $\cos \Phi = 0.8$ (16.7, 25 & 50/60 Hz)	I_{bc} [A]	4,200		-		200
Maximum making capacity						
- DC current, $\tau = 15$ ms	I_{mc} [A]	6,000 ⁽³⁾ (4)		6,000 ⁽³⁾ (4)		200
- AC current, $\cos \Phi = 0.8$ (16.7, 25 & 50/60 Hz)	I_{bc} [A]	4,200		4,200		200
Rated short-time withstand current	$I_{cw/t}$ [kA]/[ms]	10 / 100		10 / 100		3 / 100
Peak short-time withstand current	\hat{I}_{cw} [kA]	10		10		3
Rated power-frequency withstand voltage (50 Hz/1min)						
- Between main contacts (open)	U_{50} / U_a [kV _{AC}]			7.5		
- Main circuit (closed) to earth	U_{50} / U_s [kV _{AC}]			9.5		

⁽¹⁾ For Permanent Magnet Synchronous Motor applications and rated operational voltage >2,000 V_{AC}, please refer to the brochure SA003724 Brochure_Contactors_BMS_3 poles.
⁽²⁾ At T_{amb} = +40°C and tested with HV connections with current density 1.7 A/mm². For higher frequency, please contact Sécheron. ⁽³⁾ With arc chute type A ⁽⁴⁾ with Arc chute B

LOW VOLTAGE CIRCUIT

Control circuit

Nominal supply voltage ⁽⁴⁾	U_n [V _{DC}]	24 to 220	24 to 220
Nominal control voltage ⁽⁴⁾	U_{EF} [V _{DC}]	24 to 110	24 to 110
Range of voltage		[0.7 - 1.25] U _n	[0.7 - 1.25] U _n
Nominal closing power ⁽⁴⁾ ⁽⁵⁾	P_c [W]	≤ 37, ≤ 60, ≤ 80, ≤ 250, ≤ 400	40
Nominal holding power ⁽⁴⁾ ⁽⁵⁾	P_h [W]	≤ 4, ≤ 6, ≤ 10, ≤ 37	-
Mechanical closing time ⁽⁵⁾	t_{cc} [ms]	100 to 130	50
Mechanical opening time ⁽⁵⁾	t_{co} [ms]	50 to 70	10

⁽⁴⁾ For detailed values based on BMS configuration, please refer to page 9 • ⁽⁵⁾ At U_n and T_{amb} = +20°C.

Auxiliary switches

Type of contacts		Potential free (PF)
Rated voltage	[V _{DC}]	24 to 220
Conventional thermal current	I_{th} [A]	10
Utilization category according to EN60947		
- AC-15 230 V _{AC}		1.0 A
- DC-13 110 V _{DC}		0.5 A
Minimum let-through current at 24 Vdc ⁽⁶⁾	[mA]	≥ 10 (silver contacts) or 4 ≤ I < 10 (gold contacts)

⁽⁶⁾ For a dry and clean environment.

Low voltage interface

Control circuits	Direct on coil or Wago terminal (based on product configuration)
Auxiliary switches	Direct on switches

Insulation

Rated power-frequency withstand voltage (50 Hz / 1min)		
- LV circuit to earth	U_{50} / U_a [kV]	1.5

OPERATING CONDITIONS

Installation		Indoor
Altitude	[m]	≤ 2,000
Working ambient temperature	T _{amb} [°C]	- 40 to + 70
Humidity		95% at + 40°C
Pollution degree		PD3 ⁽⁷⁾
Minimum mechanical durability	N Cycles	2 millions 1 million 2 millions 1 million 2 millions

⁽⁷⁾ for BMS...08 3 poles: PD3 (at U_i/U_{Nm} = 3,600 V), PD2 (at U_i/U_{Nm} = 4,800 V)

PRODUCT INTEGRATION

MAIN DIMENSIONS

HV connections	M10 screws (BMS..08), M12 (BMS..10)
Earth connections	M6 screws, thread length 8mm
LV Connections	BMS control: faston or Wago terminal* BMS auxiliary switches: M3 screws
Fixing points	M8 screws

* Based on product configuration

Dimensions without tolerances are indicative. All dimensions are in mm. The maximum allowed flatness deviation of the support frame is 0.5 mm.

/// BMS09.08 / BMS18.08 & BMS09.10 / BMS18.10 ARC CHUTE TYPE A

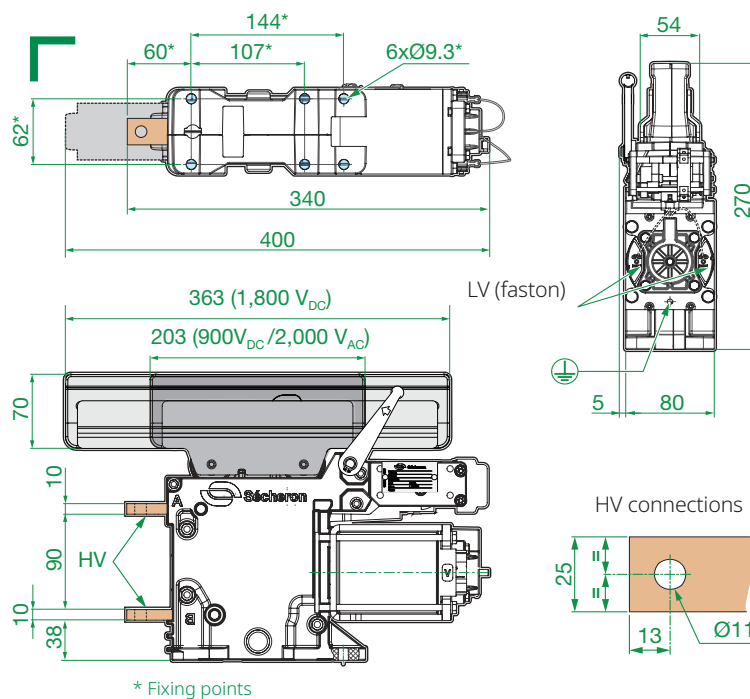

* Fixing points

BMS..08

1-POLE
Horizontal
installation only

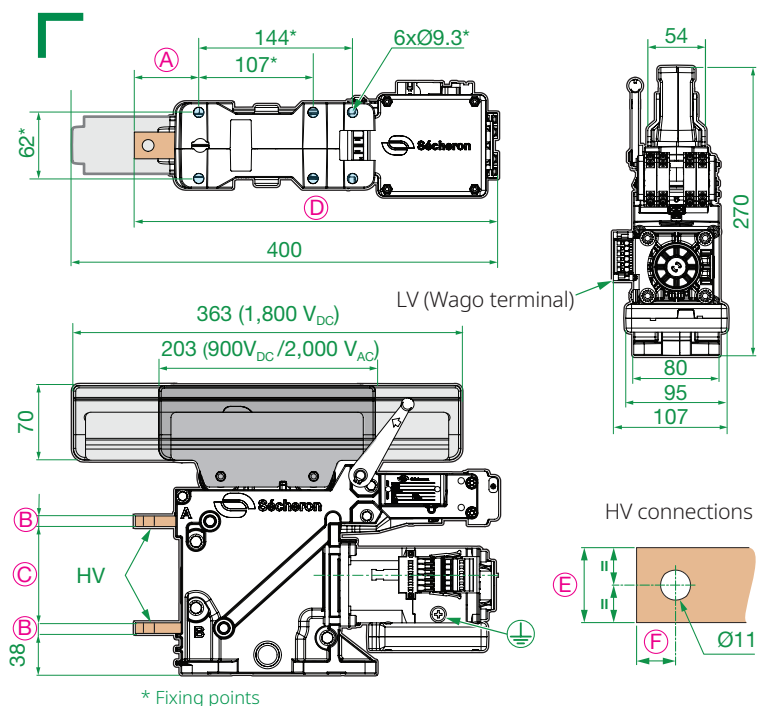
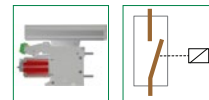

* Fixing points

BMS..08/BMS..10

1-POLE
Horizontal/vertical
installation

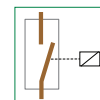

Dimensions [mm]	BMS..08	BMS..10
(A)	60	120
(B)	10	15
(C)	90	80
(D)	340	400
(E)	25	55
(F)	13	20

BMS09.08 / BMS18.08 & BMS09.10 / BMS18.10
ARC CHUTE TYPE A

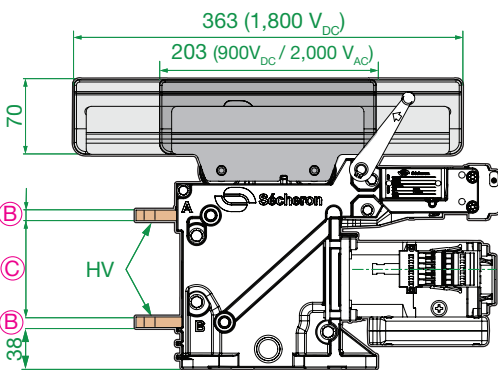
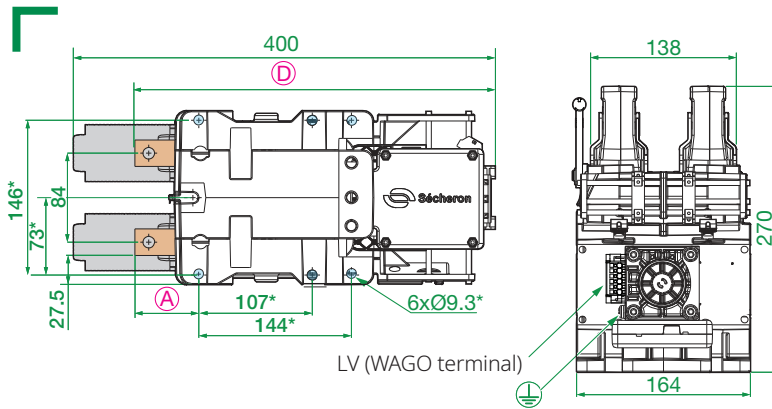

* Fixing points

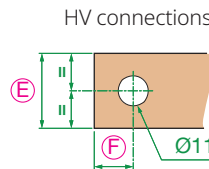

BMS..08/BMS..10
 2-POLES SYNCHRONIZED
 Horizontal/vertical
 installation

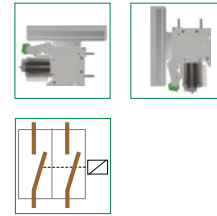

Dimensions [mm]	BMS..08	BMS..10
(A)	60	120
(B)	10	15
(C)	90	80
(D)	340	400
(E)	25	55
(F)	13	20

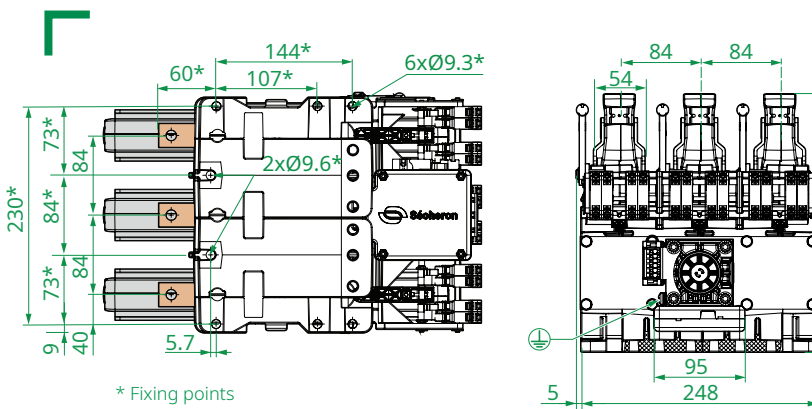

* Fixing points

BMS..08
 3-POLES
 Horizontal/vertical
 installation

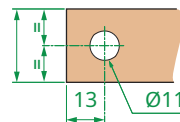
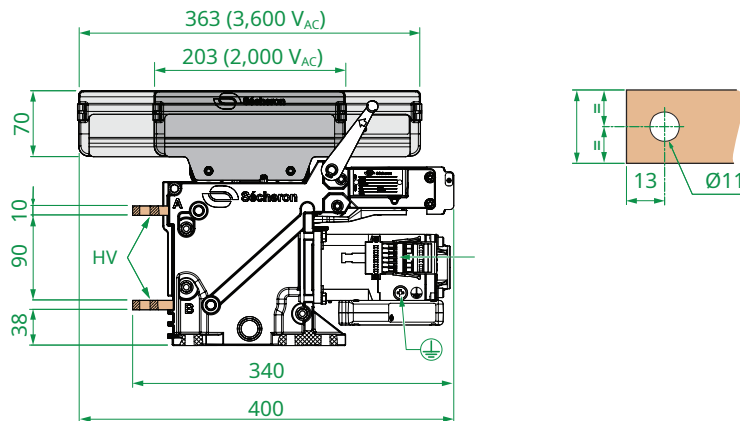
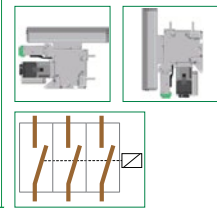

/// BMS09.08 / BMS18.08 & BMS09.10 / BMS18.10 ARC CHUTE TYPE B

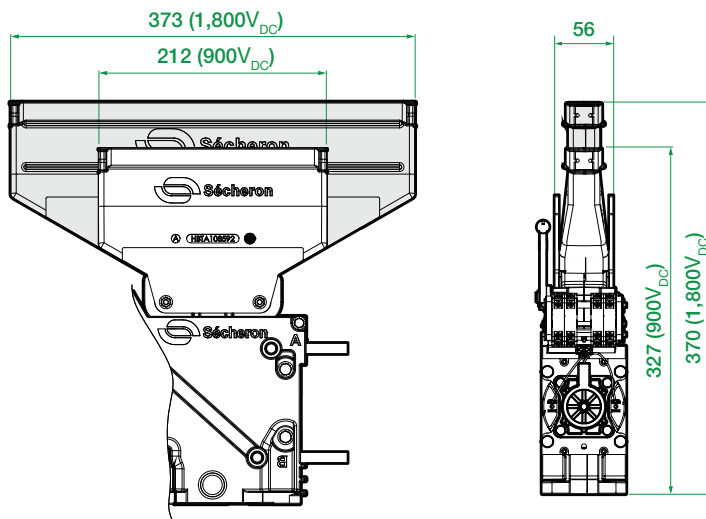

Installed only on 1 and 2 poles configurations. All dimensions with arc chute type A (refer to page 5-6) are valid for contactors equipped with arc chute type B, except for the dimensions shown below.

BMS..08/BMS..10

1-POLE
Horizontal/vertical
installation

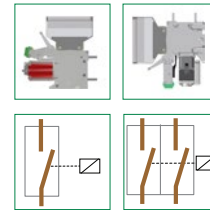

INSULATION DISTANCES AND WEIGHTS

BMS contactors have been homologated according to IEC60077-2 with the following insulation distances.

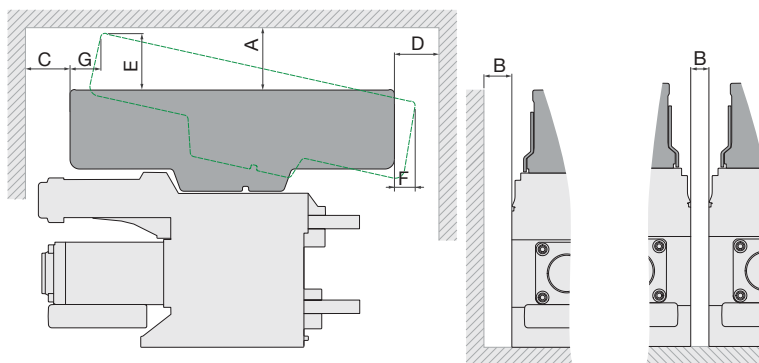

BMS type	Weight: ± 1 kg [kg]				
	pole				
	1		2		3
	...08	...10	...08	...10	...08
BMS09... A	9	10	15	17	21
BMS18... A	10	12	17	21	25
BMS09... B	10	11	17	19	-
BMS18... B	10	13	21	23	-

contactor type	Breaking current	Arc chute type	Insulating distance [mm]								Arc chute removal distance [mm]		
			To earthed wall				To insulating wall				E	F	G
			A	B	C	D	A	B	C	D			
BMS09...	≤ 800 A	A	75	10	75	75	40	10	40	40	70	30	35
	> 800 A		○ ⁽¹⁾	○ ⁽¹⁾	○ ⁽¹⁾	○ ⁽¹⁾	75	10	75	75			
BMS18...	≤ 800 A	A	75	10	75	75	40	10	40	40	90	20	40
	> 800 A		○ ⁽¹⁾	○ ⁽¹⁾	○ ⁽¹⁾	○ ⁽¹⁾	75	10	75	75			
BMS09...	≤ 800 A	B	40	10	40	40	20	10	20	20	70	45	50
	> 800 A		○ ⁽¹⁾	○ ⁽¹⁾	○ ⁽¹⁾	○ ⁽¹⁾	40	10	40	40			
BMS18...	≤ 800 A	B	40	10	40	40	20	10	20	20	80	20	80
	> 800 A		○ ⁽¹⁾	○ ⁽¹⁾	○ ⁽¹⁾	○ ⁽¹⁾	40	10	40	40			

⁽¹⁾ Distances on request according to your application

AUXILIARY CONTACTS CONFIGURATION

**BMS..08/ Optional
BMS..10 PCC18**

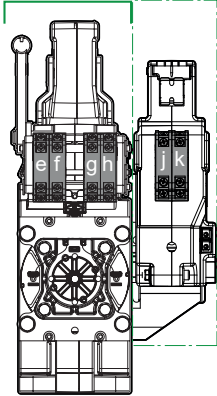

**BMS..08/
BMS..10 Optional
PCC18**

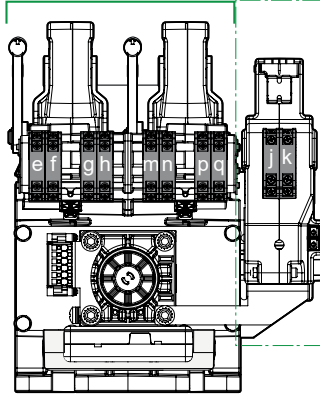

BMS..08

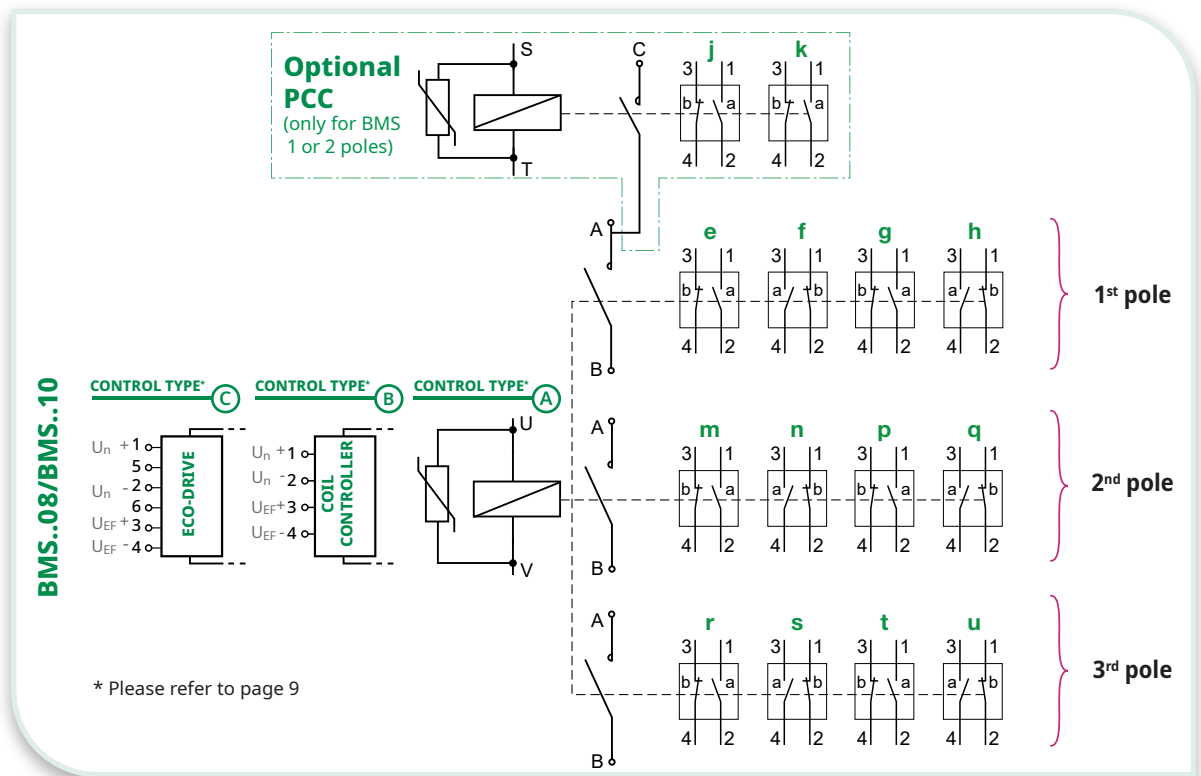
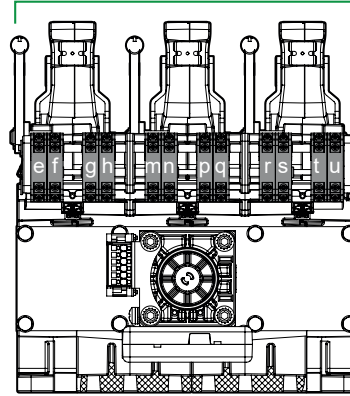

AUXILIARY SWITCH POSITION PER POLE

Function of the selected quantity of poles and of auxiliary switches per BMS's pole, the location of the switches will be as follows:

	BMS												PCC18	
	1 st pole				2 nd pole				3 rd pole				1 pole	
1 switch / pole				g				p				t	j	
2 switches / pole			f	g			n	p			s	t	j	k
3 switches / pole	e	f	g		m	n	p		r	s	t			
4 switches / pole	e	f	g	h	m	n	p	q	r	s	t	u		

LOW VOLTAGE CONTROL DIAGRAM

BMS CONFIGURATION ⁽¹⁾		Nominal supply voltage ⁽²⁾ U_n [V _{DC}]	Nominal control voltage ⁽²⁾ U_{EF} [V _{DC}]	Closing power (P_c) / Holding power (P_h) [W] / [W]	Control type	Optional PCC18 ⁽³⁾ Supply voltage U_n [V _{DC}]
BMS..08 horizontal installation only	1 pole	24, 32, 36, 48, 72, 84, 110, 220	N.A.	≤ 37 / ≤ 37	(A)	24, 48, 72, 84, 110, 220 ⁽⁴⁾
BMS..08 horizontal / vertical installation	1 pole	[24-36], [48-110]	[24-110]	≤ 60 / ≤ 4	(B)	
BMS..10 horizontal / vertical installation				≤ 80 / ≤ 4		
BMS..08, BMS..10 horizontal / vertical installation	2 poles	[24-36]	[24-110]	≤ 250 / ≤ 6	(C)	
		[48-110]			(B)	
BMS..08 horizontal / vertical installation	3 poles	[72-110]	[24-110]	≤ 400 / ≤ 10	(B)	

⁽¹⁾ For details refer to pages 5 & 6. • ⁽²⁾ Control voltage U_{EF} and supply voltage U_n can be different. • ⁽³⁾ Horizontal installation. • ⁽⁴⁾ Other voltages on request.

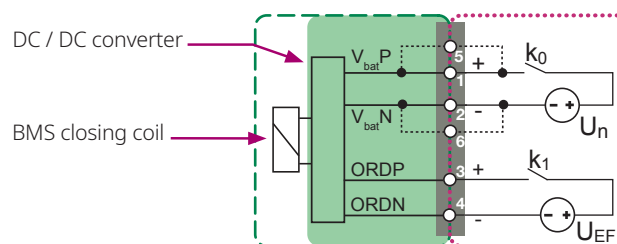
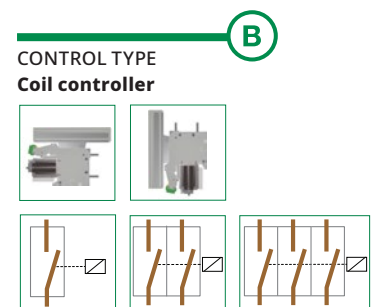
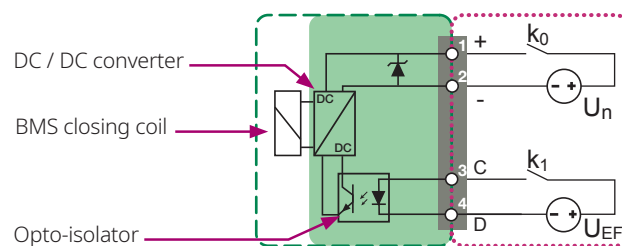
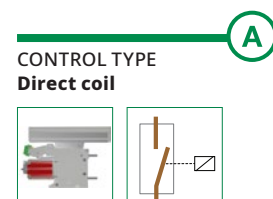
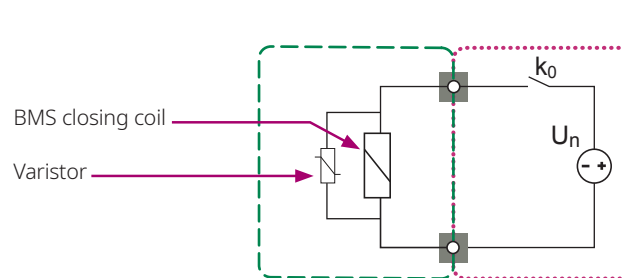

--- Sécheron's scope
- - - Customer's scope

Low voltage interface
Coil controller

U_n : DC power supply
 U_{EF} : Control voltage
 k_0 : Supply relay
 k_1 : Control relay

OPTIONS

(SUBJECT TO ADDITIONAL COSTS)

INTEGRATED CHARGING CONTACTOR (PCC18)

Line contactors and charging contactors are usually operated sequentially and mounted side by side in dedicated line breaker boxes,

or directly in traction converters. Therefore, delivering an integrated unit combining both functions, line contactor type BMS and charging

contactor type PCC18, brings an added value to car builders, as it reduces their engineering, logistic and assembly efforts.

MAIN BENEFITS

- ✓ Optimized for the dedicated charging function.
- ✓ One single unit with integration of line and charging contactors.
- ✓ Integration on all BMS contactors installed horizontally.
- ✓ Very compact solution.
- ✓ Reduced overall project costs for car builders.

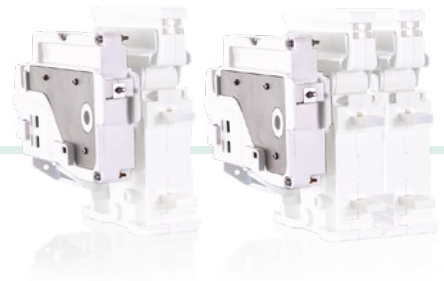

MAIN DIMENSIONS

HV connections (PCC18)	M6 screw.
Earth connections	through BMS
LV Connections	PCC18 coil: M3 screws. PCC18 auxiliary switches: M3 screws

Dimensions without tolerances are indicative. All dimensions are in mm.

The views shown here represent the **PCC18** when mounted on any horizontal **BMS..08** and **BMS..10** versions. The other dimensions of the **BMS..08** and **BMS..10** indicated on page 5 and 6 remain valid.

Additional weight
+ 3 kg

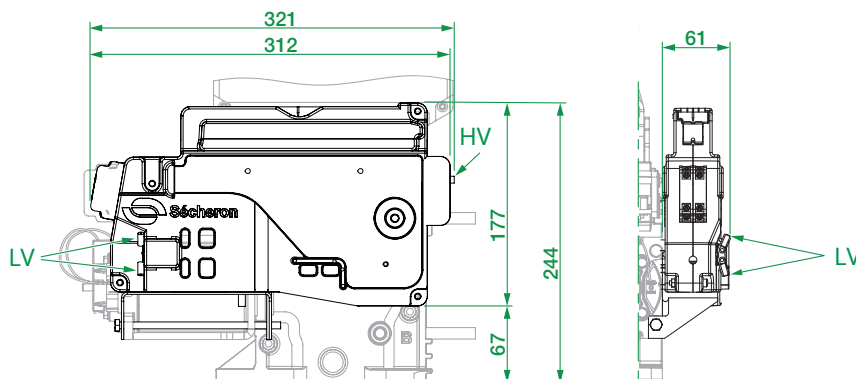
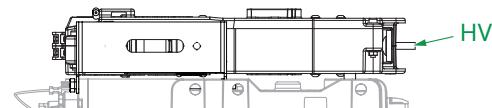

BMS + PCC

1-POLE
Horizontal installation

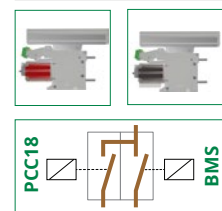

BMS + PCC

2-POLES
Horizontal installation

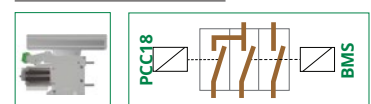

CONTROL DIAGRAM

For the control diagram, please contact Sécheron.

POWER CONTACTOR MODULE

On project base, Sécheron designs and delivers complete **Power Contactor Modules** integrating BMS and PCC contactors, but also current measurement and other components necessary to fulfill the application.

All the components are delivered mounted on a support, with implemented high voltage connections between components, and a single low voltage interface. The Power Contactor Module is available in horizontal mounting only.

This module offers the car builder simple and easy interfaces, but also simplifies its life in terms of development, logistic and installation.

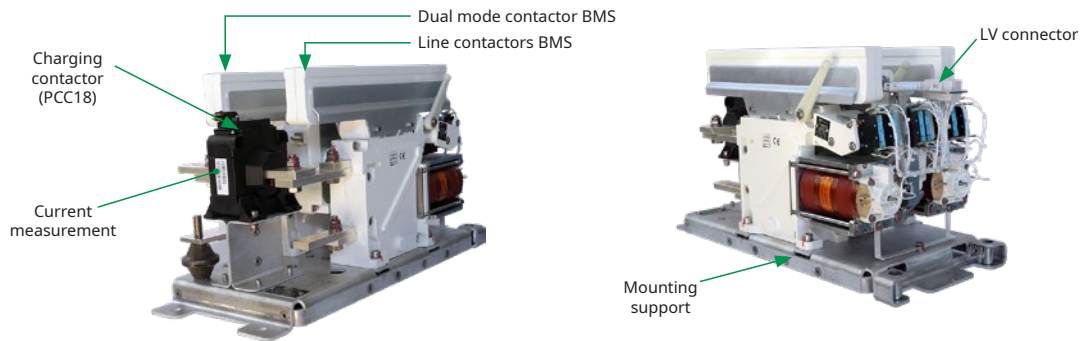

SECHERON CONTACTORS RANGE

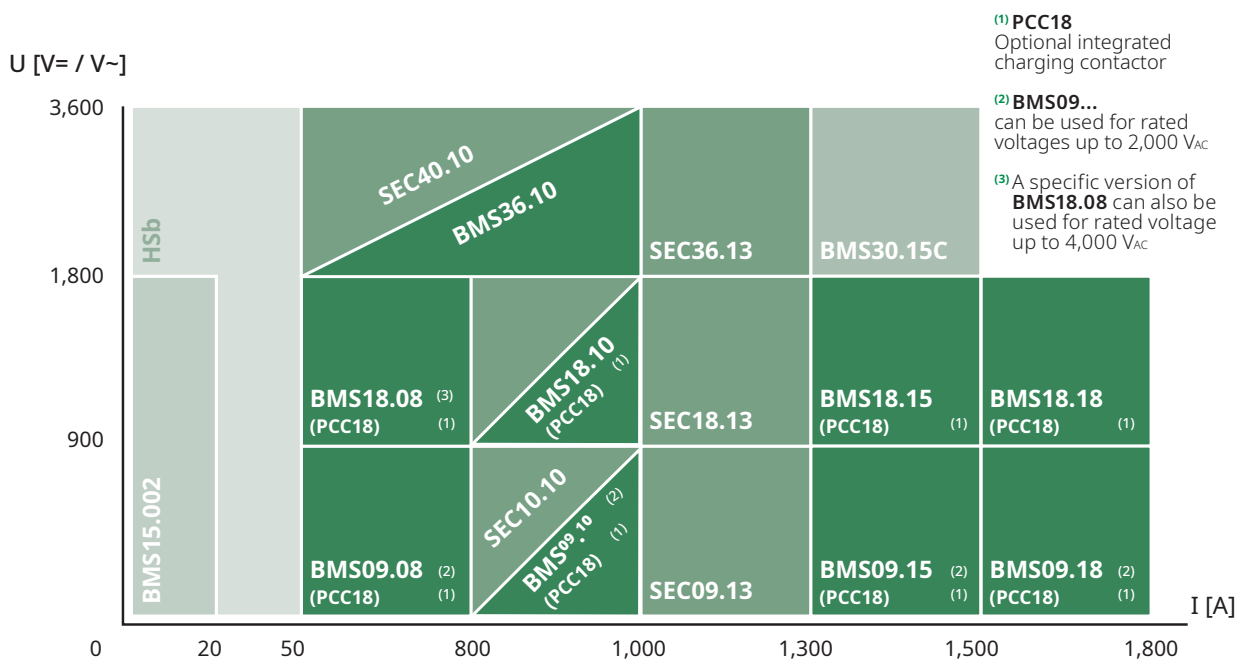

AT A GLANCE

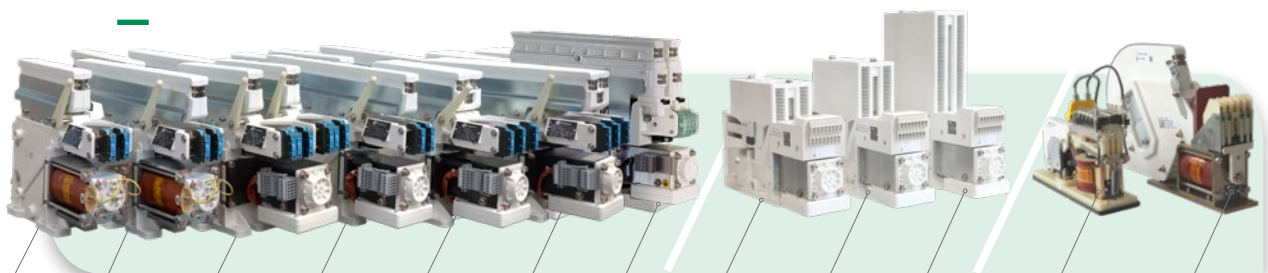

BMS 09.08 1 pole Arc chute Type A	BMS 18.08 1 pole Arc chute Type A	BMS 09.08 2 poles Arc chute Type A	BMS 18.10 1 pole Arc chute Type A	BMS 09.15 1 pole Arc chute Type A	BMS 18.18 1 pole Arc chute Type A	BMS 36.10 1 pole	SEC10.10/ SEC09.13	SEC20.10/ SEC18.13	SEC40.10/ SEC36.13	BMS15.002	HSB
---	---	--	---	---	---	----------------------------	---------------------------	---------------------------	---------------------------	------------------	------------

DESIGNATION CODE FOR ORDERING

- Be sure to establish the designation code from the latest version of our brochure by downloading it from the website: www.secheron.com.
- Be careful to write down the complete alphanumeric designation code with 17 characters when placing your order.
- For technical reasons some variants and options indicated in the designation code might not be combined, therefore validate your configuration with Sécheron before ordering.
- For other configurations not described in the brochure, please contact Sécheron.

Example of customer's choice:	BMS	18	08	A	1	Z	Ø	E	A	1	H	D	A
Line:	10	11	12	13	14	15	16	17	18	19	20	21	22

The bold characters of the designation code define the device type.

Note: some combinations may not be possible, therefore validate your configuration with Sécheron before ordering

DESIGNATION CODE

Line	Description	Designation	Standard	Options	Customer's choice
10	Product type BMS	BMS	BMS		BMS
11	Rated operational voltage	900 V _{DC} or 2,000 V _{AC}	09		
		1,800 V _{DC}	18		
12	Rated conventional free air thermal current ⁽¹⁾	800 A	08		
		1,000 A	10		
13	Arc chute type	Type A	A		
		Type B		B	
14	Number of poles	(AC or DC) 1 pole	1		
		(AC or DC) 2 poles	2		
		(only AC) 3 poles*	3		
15	Poles mechanical synchronization	(1 pole) Not applicable	Z		
		(2 & 3 poles) Synchronized	S		
16	Integrated of charging contactor type PCC18	No	Z		
		Yes		C	
17	Nominal supply voltage ⁽²⁾	24 V _{DC}	A		
	* 3 poles only available for [72 - 110 V _{DC}]	32 V _{DC}		F	
		36 V _{DC}	B		
		48 V _{DC}	C		
		72 V _{DC}	D		
		84 V _{DC}		H	
		96 V _{DC}		4	
		110 V _{DC}	E		
		220 V _{DC}		J	
18	Auxiliary contacts BMS - per pole	1a + 1b - (switch PF) - silver type	A		
		1a + 1b - (switch PF) - gold type		C	
		2a + 2b - (switch PF) - silver type		E	
		2a + 2b - (switch PF) - gold type		H	
		3a + 3b - (switch PF) - silver type		K	
		3a + 3b - (switch PF) - gold type		M	
		4a + 4b - (switch PF) - silver type		O	
		4a + 4b - (switch PF) - gold type		P	
19	Auxiliary contacts (PCC18) ⁽³⁾	(No PCC18) Not applicable	Z		
		1a + 1b - (switch PF) - silver type		1	
		1a + 1b - (switch PF) - gold type		2	
		2a + 2b - (switch PF) - silver type		3	
		2a + 2b - (switch PF) - gold type		4	
20	Installation configuration	Horizontal only	H		
		Horizontal & Vertical ⁽³⁾		V	
21	Application type	(Direct Current) DC	D		
	-	(Alternating Current) AC		A	
22	Opening BMS arc chute	Arc chute lever	A		A

⁽¹⁾ For DC and AC voltage up to 60 Hz frequency. For higher frequency, please contact Sécheron •

⁽²⁾ For the available control voltage in function of the BMS configuration, refer to table page 9. Please note that BMS is delivered with low voltage surge protection •

⁽³⁾ PCC18 is valid for horizontal mounting only and for BMS.. 1 or 2 poles. •



Sécheron SA
Rue du Pré-Bouvier 25
1242 Satigny - Geneva
CH-Switzerland

www.secheron.com
Tel: +41 22 739 41 11
Fax: +41 22 739 48 11
ess@secheron.com

Signature:

Name:

Place and date: