

CONTACTORS

Type **BMS09.15 / BMS18.15**
BMS09.18 / BMS18.18

RAIL VEHICLES / FIXED INSTALLATION

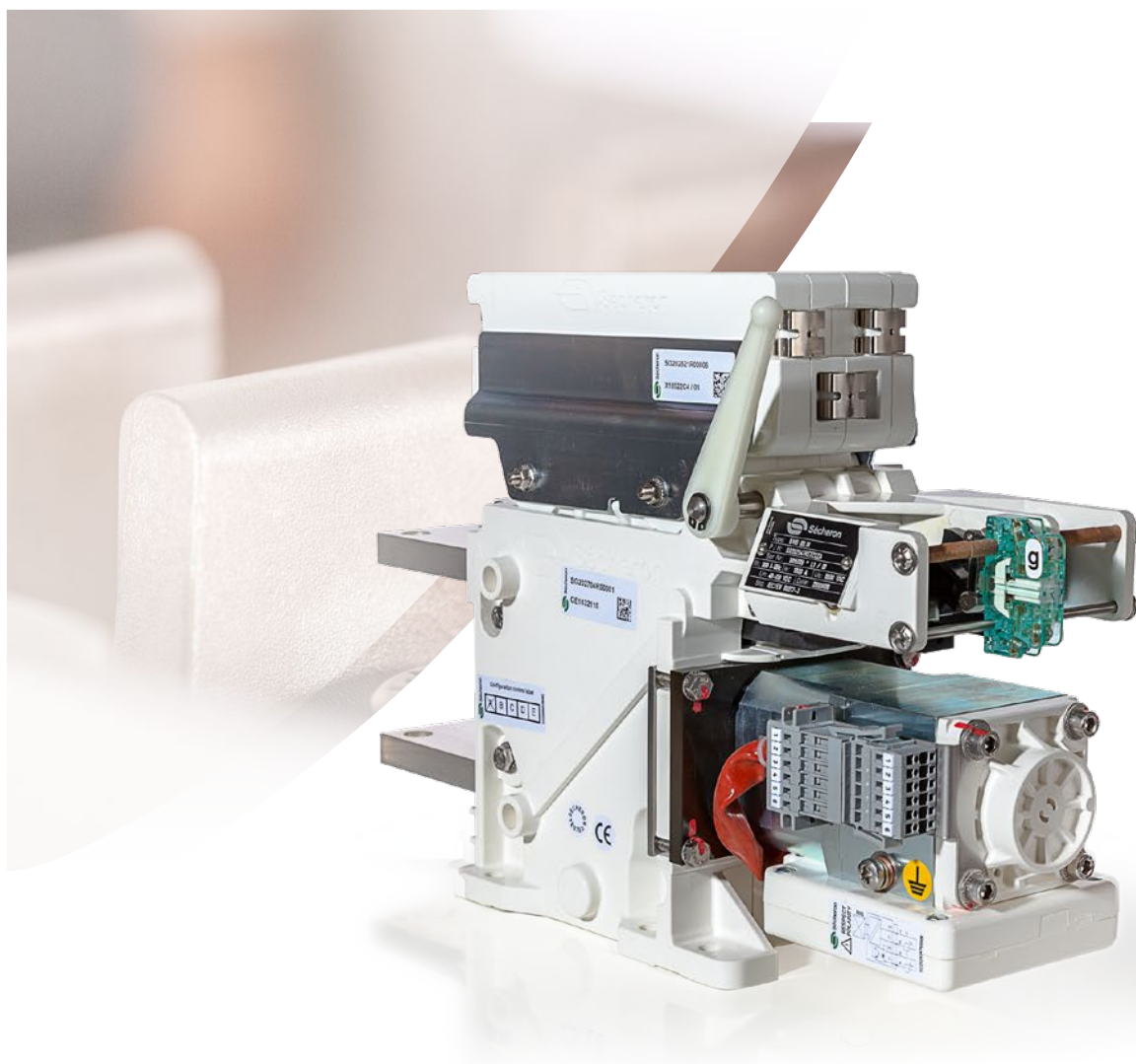

GENERAL INFORMATION

The **BMS** contactor, with more than one hundred and fifty thousands units in operation worldwide, is a contactor valued by the car builders and operators of electric traction vehicles for its strong performance level and its extremely high reliability. Taking advantages of its recognized features and design, Sécheron has modernized the BMS to make a product platform particularly well adapted to actual requirements and standards. With its high modularity, the **BMS** offers variants and options that enable our customers to find

the most appropriate version to fit their application either as a stand-alone contactor, or delivered coupled with a Sécheron dedicated charging contactor type **PCC18**. Power contactor modules, convenient to order and easy to install, are a frequent wish of our customers. Sécheron brings the best solution with “plug & play” units gathering line and charging contactors, but also current measurement and customised high voltage and low voltage interfaces.

APPLICATIONS, TYPICAL EXAMPLES

- Line contactors for DC vehicles.

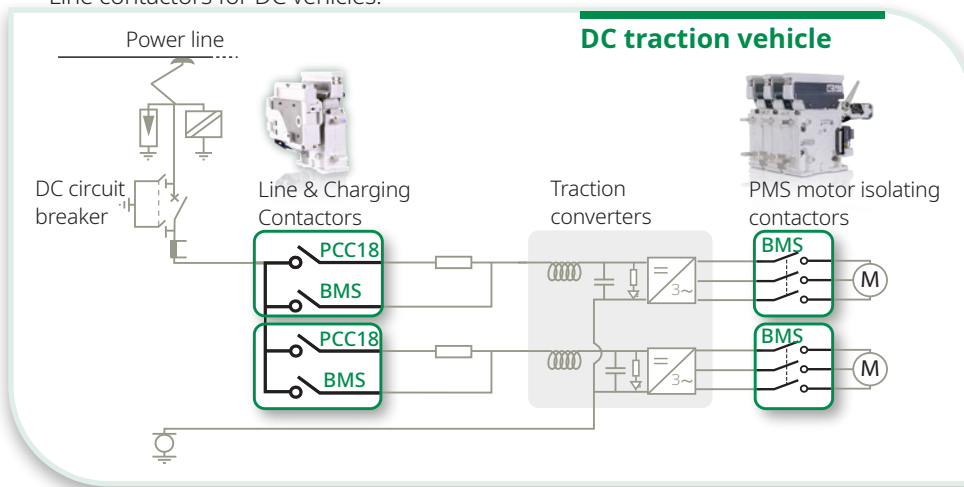

- Separation/line contactors for AC vehicles.

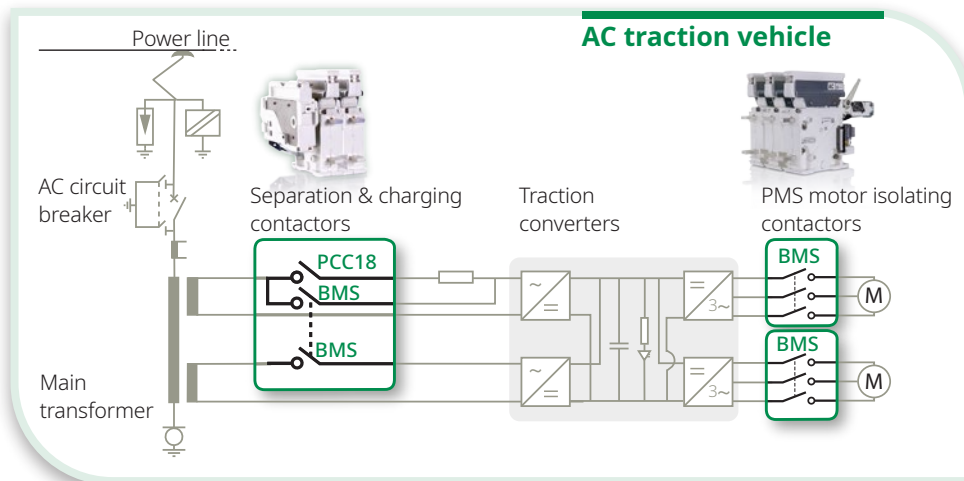

- Other applications for locomotives, trains, EMUs, tramways/light rail vehicles, including dual mode rail vehicles with battery.
- Contactors for DC traction power substations and other industrial fields.

MAIN FEATURES

- Normally open and bi-directional contactor.
- Rated operation voltage 900 V_{DC} or 1,800 V_{DC} / 2,000 V_{AC}.
- Conventional free air thermal current 1,500 A or 1,800 A.
- Available in 1 or 2 poles.
- Low voltage control coil protection against surges.
- Suitable for ambient temperature from -40°C to +70°C.
- Reference standards: EN/IEC 60077-1/-2, EN/IEC 61373, EN 45545, EN 50657.

MAIN BENEFITS

- ✓ Compact size and low weight.
- ✓ No critical current.
- ✓ High mechanical and electrical durability.
- ✓ Horizontal or vertical mounting to match vehicle's installation constraints.
- ✓ High modularity of the range.
- ✓ Possible integration of optional charging contactor type PCC18 directly on BMS separation/line contactor.
- ✓ Low maintenance requirements with easy access to the main contacts for replacement.
- ✓ Worldwide service proven.

CONTACTOR CONFIGURATIONS

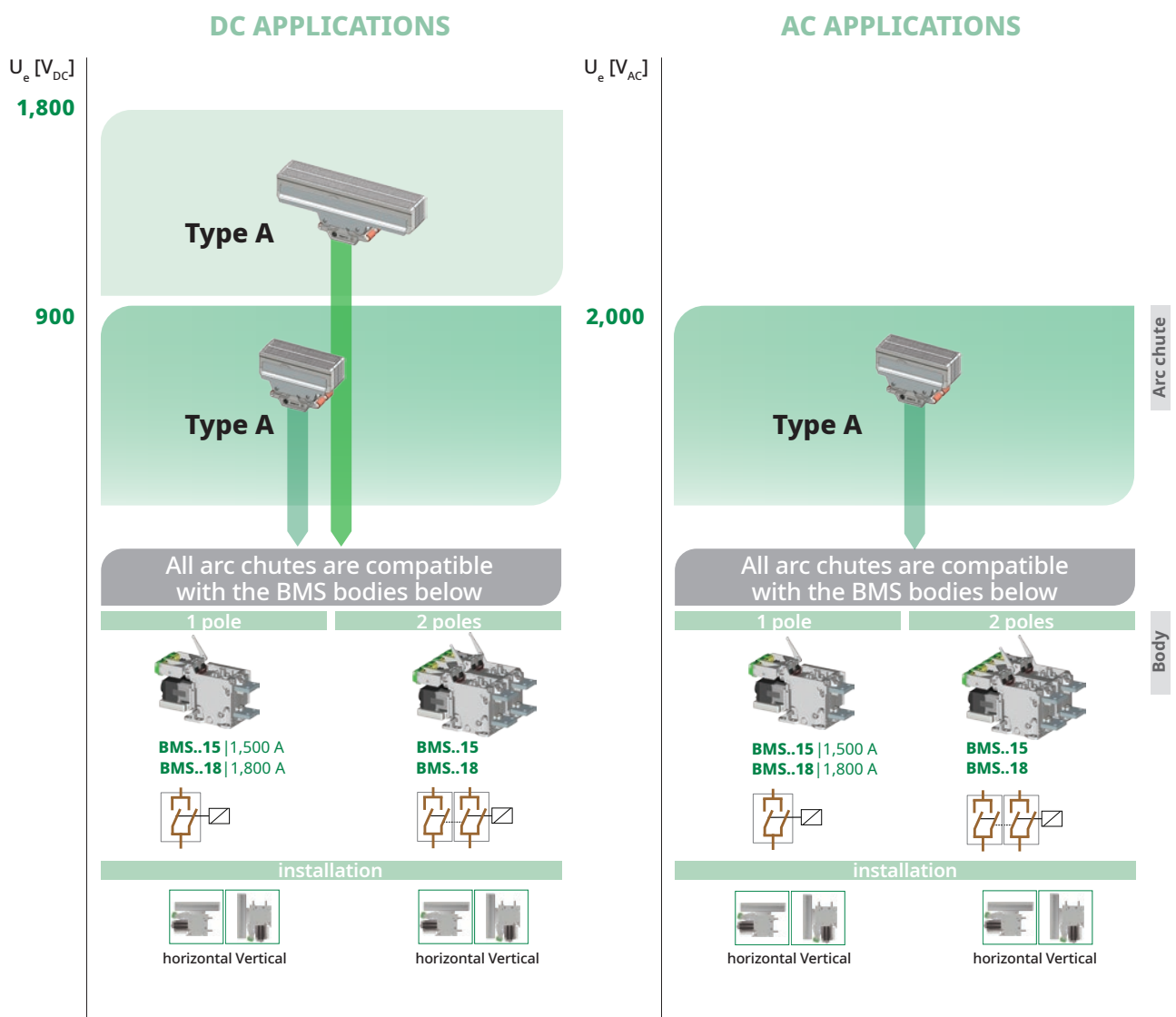

DATA FOR PRODUCT SELECTION

Symbol	Unit	BMS 09.15	BMS 09.18	BMS 18.15	BMS 18.18	PCC18
MAIN HIGH VOLTAGE CIRCUIT						
Pole quantity		1, 2	1, 2	1, 2	1, 2	1
Component category		A2				
Type of main contact		Normally Open				
Rated operational voltage						
- DC voltage	U_e / U_r [V]	900		1,800		1,800
- AC voltage (16.7, 25, 50/60, ...Hz ⁽¹⁾)	[V]	2,000		-		2,000
Rated insulation voltage	U_i / U_{Nm} [V _{DC}]	2,300		2,300		2,300
	[V _{AC}]	2,000		-		2,000
Conventional free air thermal current ⁽²⁾	I_{th} [A]					
- DC voltage & AC voltage (16.7, 25, 50/60 Hz)		1,500	1,800	1,500	1,800	N.A.
Rated operational current/operational frequency						
-DC	I_e / I_r [A]	800 / C1 / 500 / C2		800 / C1 / 500 / C2		100
-AC	I_e / I_r [A]	1,500 / C3	1,800 / C2	-	-	100
Maximum breaking capacity						
- DC current, $\tau = 15$ ms	I_{bc} [A]	3,200		2,300		200
- AC current, $\cos \Phi = 0.8$ (16.7, 25 & 50/60 Hz)	I_{bc} [A]	4,200		-		200
Maximum making capacity						
- DC current, $\tau = 15$ ms	I_{mc} [A]	10,000		10,000		100
- AC current, $\cos \Phi = 0.8$ (16.7, 25 & 50/60 Hz)	I_{bc} [A]	7,000		-		200
Rated short-time withstand current	$I_{cw/t}$ [kA]/ [ms]	15 / 100		15 / 100		3 / 100
Peak short-time withstand current	\hat{I}_{cw} [kA]	20		20		3
Rated power-frequency withstand voltage (50 Hz/1min)						
- Between main contacts (open)	U_{50} / U_a [kV _{AC}]			7.5		
- Main circuit (closed) to earth	U_{50} / U_a [kV _{AC}]			9.5		

⁽¹⁾ At $T_{amb} = +40^\circ\text{C}$ for DC and AC voltage up to 60 Hz and tested with HV connections with current density 1.7A/mm².

⁽²⁾ For higher values, please contact Sécheron.

LOW VOLTAGE CIRCUIT

Control circuit

Nominal supply voltage ⁽³⁾	U_n [V _{DC}]	24 to 110	24 to 110
Nominal control voltage ⁽³⁾	U_{EF} [V _{DC}]	24 to 110	24 to 110
Range of voltage		[0.7 - 1.25] U_n	[0.7 - 1.25] U_n
Nominal closing power ^{(3) (4)}	P_c [W]	≤ 325 (1 pole), ≤ 650 (2 poles)	40 ⁽³⁾
Nominal holding power ⁽⁴⁾	P_h [W]	≤ 6 (1 pole), ≤ 12 (2 poles)	-
Mechanical closing time	t_{cc} [ms]	100	50
Mechanical opening time ⁽⁴⁾	t_{co} [ms]	60	10

⁽³⁾ For detailed values based on BMS configuration, please refer to page 8 • ⁽⁴⁾ At U_n and $T_{amb} = +20^\circ\text{C}$.

Control circuit

Type of contacts		Potential free (PF)
Rated voltage	[V _{DC}]	24 to 110
Conventional thermal current	I_{th} [A]	10
Utilization category according to EN60947		
- AC-15 230 V _{AC}		1.0 A
- DC-13 110 V _{DC}		0.5 A
Minimum let-through current at 24 V _{DC} ⁽⁵⁾	[mA]	≥ 10 (silver contacts) or $4 \leq I < 10$ (gold contacts)

⁽⁵⁾ For a dry and clean environment.

Low voltage interface

Control circuits	Wago terminal
Auxiliary switches	Direct on switches (M3 screws)

Insulation

Rated power-frequency withstand voltage (50 Hz / 1min)		
- LV circuit to earth	U_{50} [kV]	1.5

OPERATING CONDITIONS

Installation		Indoor
Altitude	[m]	$\leq 2,000$
Working ambient temperature	T_{amb} [°C]	- 40 to + 70
Humidity		95% at + 40°C
Pollution degree		PD3
Minimum mechanical durability	N Cycles	2 millions 1 million 2 millions 1 million 2 millions

PRODUCT INTEGRATION

MAIN DIMENSIONS

HV connections	M12 screws
Earth connections	M6 screws, thread length 8mm
LV Connections	Wago terminal
	BMS auxiliary: switches M3 screws
Fixing points	M8 screws

* Based on product configuration

Dimensions without tolerances are indicative. All dimensions are in mm. The maximum allowed flatness deviation of the support frame is 0.5 mm.

/// BMS09.15 / BMS18.15 & BMS09.18 / BMS18.18 (ARC CHUTE TYPE A)

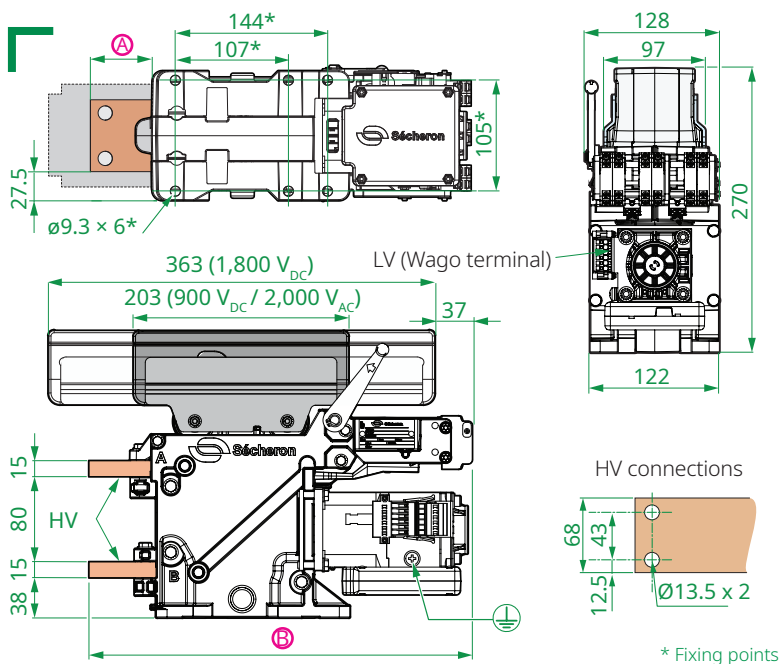

BMS..15/BMS..18

1-POLE
Horizontal/Vertical
installation only

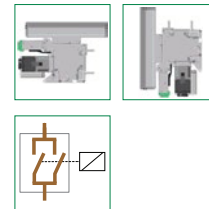

Dimensions [mm]	BMS..15	BMS..18
(A)	58	98
(B)	360	400

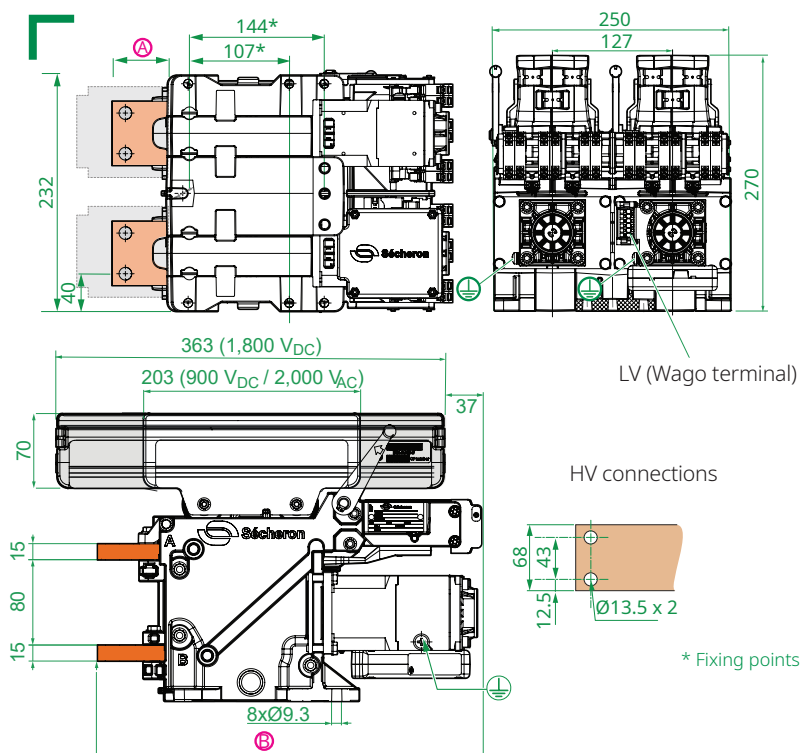

BMS..15/BMS..18

2-POLES
Horizontal/Vertical
installation

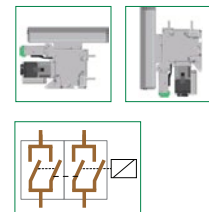

Dimensions [mm]	BMS..15	BMS..18
(A)	58	98
(B)	360	400

OVERVIEW OF THE BMS..15 / BMS..18 RANGE

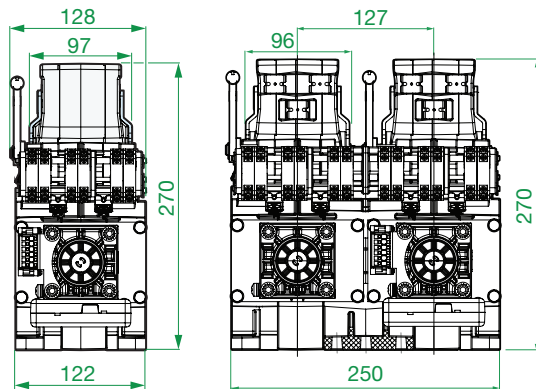

1-pole
 BMS09.15A
 BMS09.15A
 BMS18.15A
 BMS18.18A
 (Horizontal / Vertical)

2-poles
 BMS09.15A
 BMS09.15A
 BMS18.15A
 BMS18.18A
 (Horizontal / Vertical)

INSULATION DISTANCES AND WEIGHTS

BMS contactors have been homologated according to IEC60077-2 with the following insulation distances.

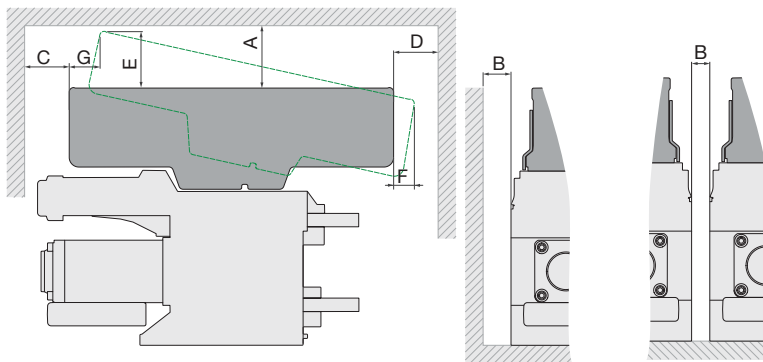

BMS type	Weight: ± 1 kg [kg]			
	pole			
	1		2	
	...15	...18	...15	...18
BMS09...A	14	15	28	30
BMS18...A	15	16	29	31

contactor type	Breaking current	Arc chute type	Insulating distance [mm]								Arc chute removal distance [mm]		
			To earthed wall				To insulating wall						
			A	B	C	D	A	B	C	D	E	F	G
BMS09...	≤ 800 A	A	125	10	75	75	75	10	40	40	70	30	35
	> 800 A		○ ⁽¹⁾	○ ⁽¹⁾	○ ⁽¹⁾	○ ⁽¹⁾	125	10	75	75			
BMS18...	≤ 800 A	A	125	10	75	75	75	10	40	40	90	20	40
	> 800 A		○ ⁽¹⁾	○ ⁽¹⁾	○ ⁽¹⁾	○ ⁽¹⁾	125	10	75	75			

⁽¹⁾ Distances on request according to your application

AUXILIARY CONTACTS CONFIGURATION

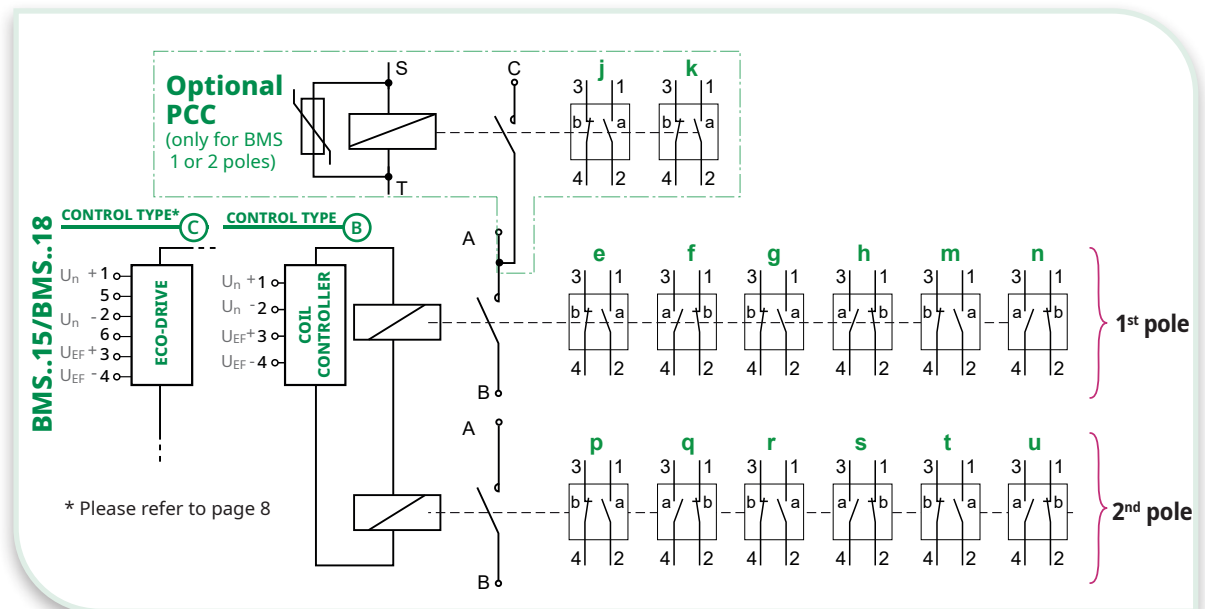
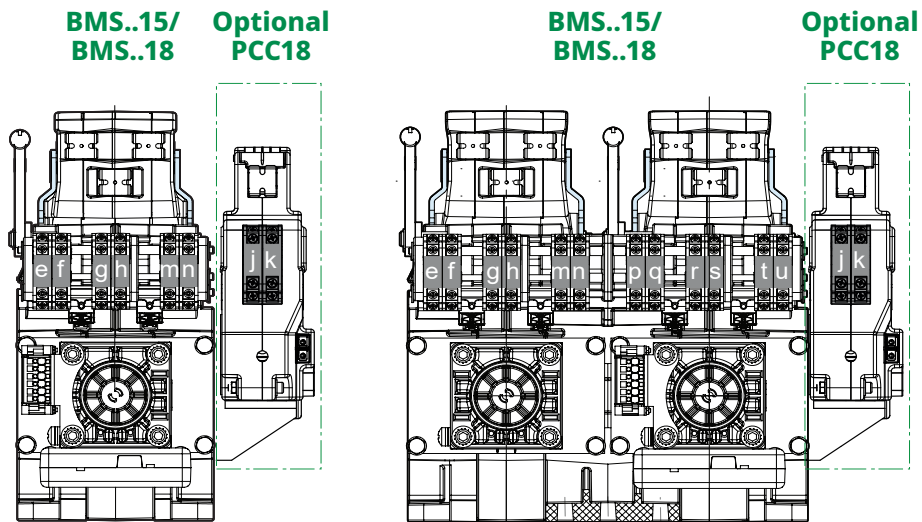

AUXILIARY SWITCH POSITION PER POLES

Function of the selected quantity of poles and of auxiliary switches per BMS's pole, the location of the switches will be as follows:

		BMS				PCC18	
		1 st pole		2 nd pole		1 pole	
1 switch	/ pole		g		r	j	
2 switches	/ pole	f		m	q	t	j k
3 switches	/ pole	f	g	m	q	r	t
4 switches	/ pole	f	g	m	n	q	r
						t	u

For more poles, please contact Sécheron

LOW VOLTAGE CONTROL DIAGRAM

BMS CONFIGURATION ⁽¹⁾		Nominal supply voltage ⁽²⁾ U_n [VDC]	Nominal control voltage ⁽²⁾ U_{EF} [VDC]	Closing power (P_c) / Holding power (P_h) [W] / [W]	Control type	Optional PCC18 ⁽³⁾ Supply voltage U_n [VDC]
BMS..15, BMS..18 horizontal / vertical installation	1 pole	[24-36]	[24-110]	≤ 325 / ≤ 6	(C)	24, 48, 72, 84, 110 ⁽⁴⁾
BMS..15, BMS..18 horizontal / vertical installation	1 pole	[48-110]	[24-110]	≤ 325 / ≤ 6	(B)	
	2 poles	[110]	[24-110]	≤ 650 / ≤ 12	(B)	

⁽¹⁾ For details refer to pages 5 & 6. • ⁽²⁾ Control voltage U_{EF} and supply voltage U_n can be different. • ⁽³⁾ Horizontal installation.
• ⁽⁴⁾ Other voltages on demand.

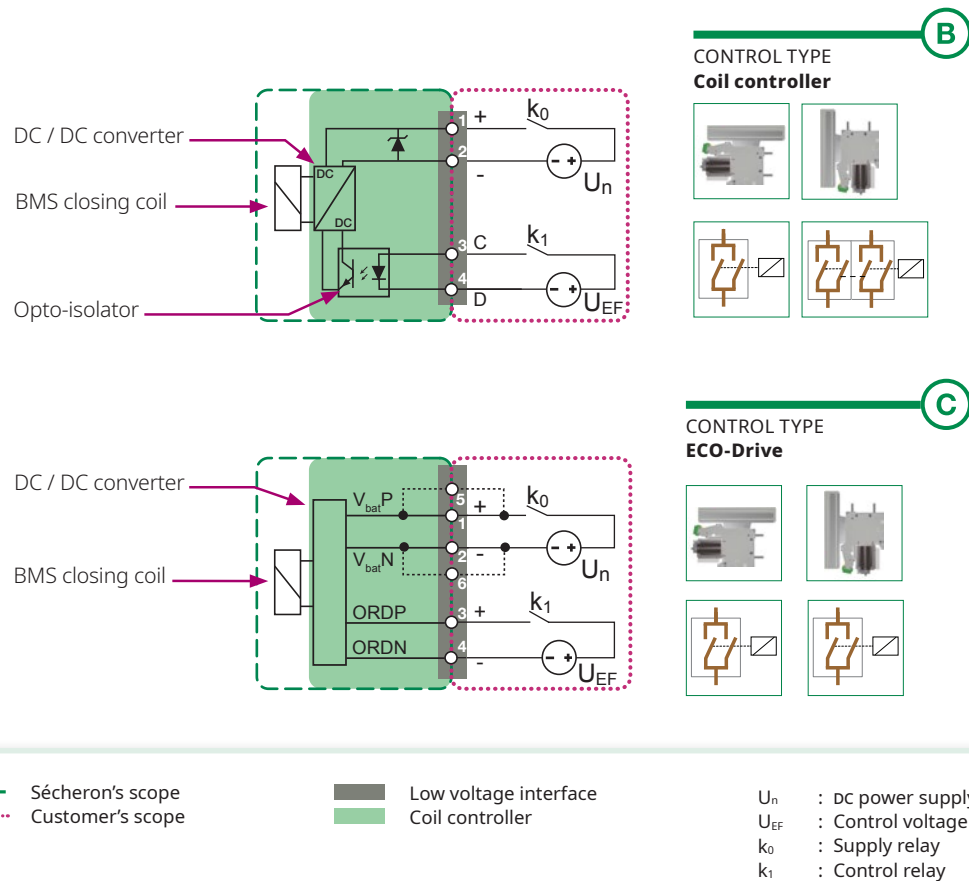

OPTIONS

(SUBJECT TO ADDITIONAL COSTS)

INTEGRATED CHARGING CONTACTOR (PCC18)

Line contactors and charging contactors are usually operated sequentially and mounted side by side in dedicated line breaker boxes,

or directly in traction converters. Therefore, delivering an integrated unit combining both functions, line contactor type BMS and charging

contactor type **PCC18**, brings an added value to car builders, as it reduces their engineering, logistic and assembly efforts.

MAIN BENEFITS

- ✓ Optimized for the dedicated charging function.
- ✓ One single unit with integration of line and charging contactors.
- ✓ Integration on all BMS contactors installed horizontally.
- ✓ Very compact solution.
- ✓ Reduced overall project costs for car builders.

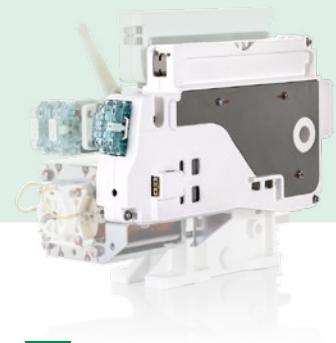

MAIN DIMENSIONS

HV connections (PCC18)	M6 screw.
Earth connections	through BMS
LV Connections	PCC18 coil: M3 screws. PCC18 auxiliary switches: M3 screws

Dimensions without tolerances are indicative. All dimensions are in mm.

The views shown here represent the **PCC18** when mounted on any horizontal **BMS..08** and **BMS..10** versions. The other dimensions of the **BMS..08** and **BMS..10** indicated on page 5 and 6 remain valid.

Additional weight
+ 3 kg

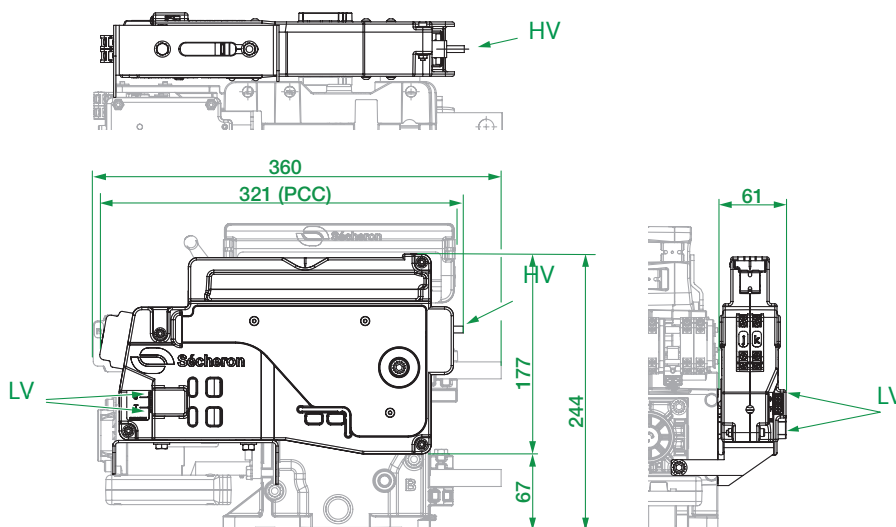

BMS + PCC

1-POLE
Horizontal installation

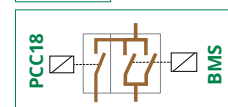

BMS + PCC

2-POLES
Horizontal installation

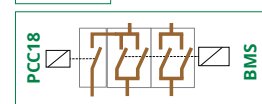

CONTROL DIAGRAM

For the control diagram, please contact Sécheron.

POWER CONTACTOR MODULE

On project base, Secheron designs and delivers complete **Power Contactor Modules** integrating BMS and PCC contactors, but also current measurement and other components necessary to fulfill the application.

All the components are delivered mounted on a support, with implemented high voltage connections between components, and a single low voltage interface. The Power Contactor Module is available in horizontal mounting only.

This module offers the car builder simple and easy interfaces, but also simplifies its life in terms of development, logistic and installation.

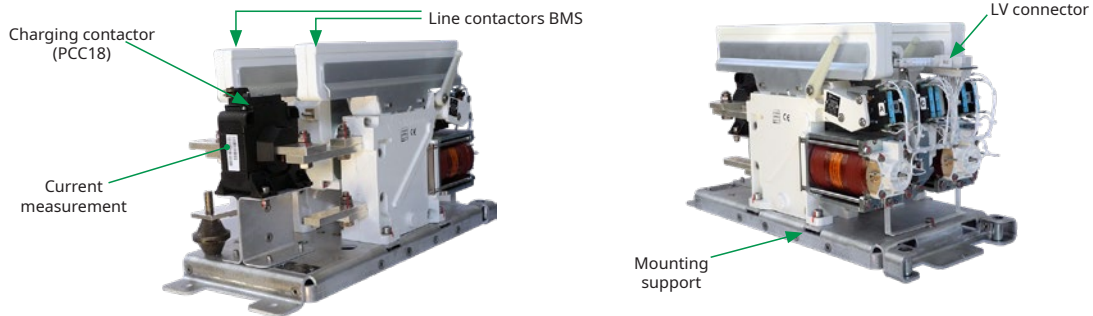

SECHERON CONTACTORS RANGE

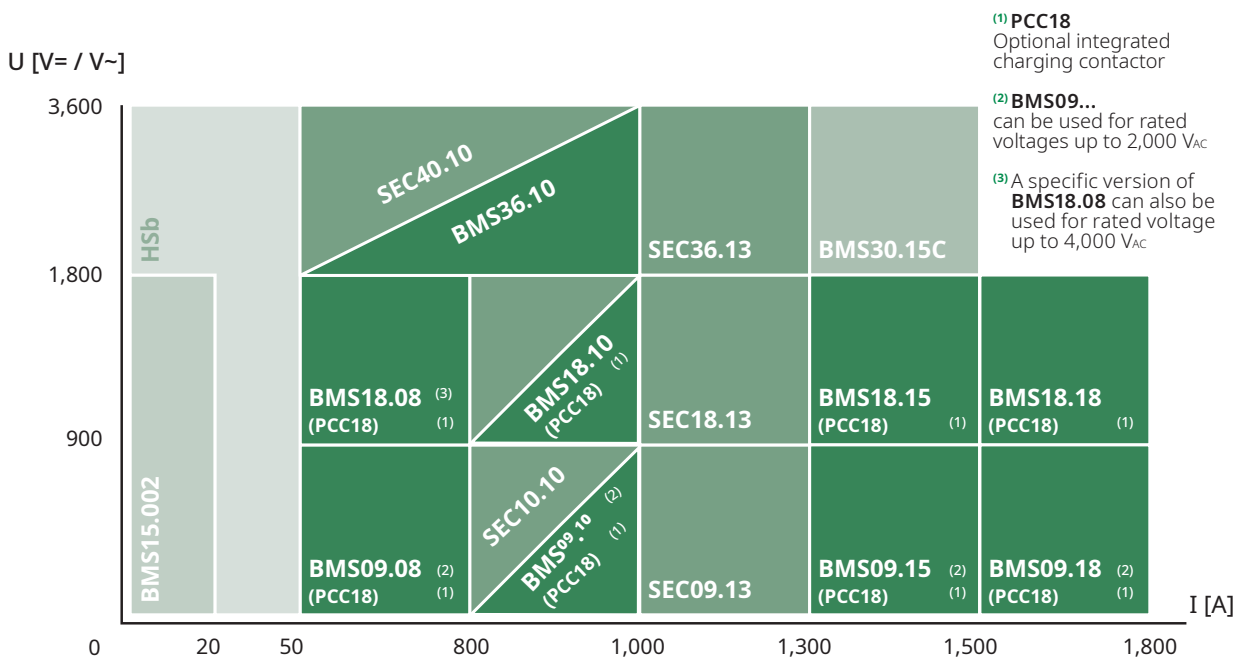

AT A GLANCE

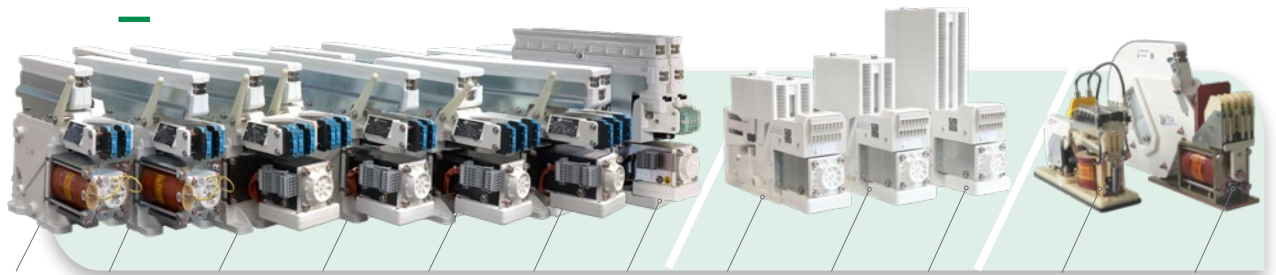

BMS 09.08 1 pole Arc chute Type A	BMS 18.08 1 pole Arc chute Type A	BMS 09.08 2 poles Arc chute Type A	BMS 18.10 1 pole Arc chute Type A	BMS 09.15 1 pole Arc chute Type A	BMS 18.18 1 pole Arc chute Type A	BMS 36.10 1 pole	SEC10.10/ SEC09.13	SEC20.10/ SEC18.13	SEC40.10/ SEC36.13	BMS15.002	HSB
---	---	--	---	---	---	----------------------------	---------------------------	---------------------------	---------------------------	------------------	------------

BROCHURE REFERENCE FOR OTHER SÉCHERON'S CONTACTORS



BMS..08/BMS..10 Type

ROLLING STOCK
(Line/separation contactors, ...).

FIXED INSTALLATION
(depot feeder contactor...).



BMS..08 3-pole Type

ROLLING STOCK
(Line/separation contactors, ...).

FIXED INSTALLATION
(depot feeder contactor, ...).



BMS..15/BMS..18 Type

ROLLING STOCK
(Line/separation contactors, ...).

FIXED INSTALLATION
(depot feeder contactor...).



BMS.36.10 Type

ROLLING STOCK
(Line/separation contactors, ...).

FIXED INSTALLATION
(depot feeder contactor...).



SEC Type

ROLLING STOCK
(Line/separation contactors, PM motor,...).

FIXED INSTALLATION
(depot feeder contactor, ...).



BMS30.15C Type

ROLLING STOCK
(Line/separation contactors, ...).

FIXED INSTALLATION
(depot feeder contactor, ...).



HS Type

ROLLING STOCK
(Charging, Heating, HVAC, ...).

FIXED INSTALLATION
(Line testing, ...).



BMS15.002 Type

ROLLING STOCK
(Charging, Heating, HVAC, ...).

FIXED INSTALLATION
(Line testing, ...).

DESIGNATION CODE FOR ORDERING

- Be sure to establish the designation code from the latest version of our brochure by downloading it from the website: www.secheron.com.
- Be careful to write down the complete alphanumeric designation code with 17 characters when placing your order.
- For technical reasons some variants and options indicated in the designation code might not be combined, therefore validate your configuration with Sécheron before ordering.
- For other configurations not described in the brochure, please contact Sécheron.

Example of customer's choice:	BMS	18	18	A	1	Z	Ø	E	A	1	H	D	A
Line:	10	11	12	13	14	15	16	17	18	19	20	21	22

The bold characters of the designation code define the device type.

DESIGNATION CODE

Line	Description	Designation	Standard	Options	Customer's choice
10	Product type	BMS	BMS		BMS
11	Rated operational voltage	900 V _{DC} or 2,000 V _{AC}	09		
		1,800 V _{DC}	18		
12	Rated conventional free air thermal current ⁽¹⁾	1,500 A	15		
		1,800 A	18		
13	Arc chute type	Type A	A		
14	Number of poles	1 pole	1		
		2 poles	2		
15	Poles mechanical synchronization	(1 pole) Not applicable	Z		
		(2 poles) Synchronized	S		
16	Integrated of charging contactor type PCC18	No	Z		
		Yes		C	
17	Nominal supply voltage ⁽²⁾	24 V _{DC}	A		
		36 V _{DC}	B		
		48 V _{DC}	C		
		72 V _{DC}	D		
		84 V _{DC}		H	
		96 V _{DC}		4	
		110 V _{DC}	E		
18	Auxiliary contacts BMS - per pole	1a + 1b - (switch PF) - silver type	A		
		1a + 1b - (switch PF) - gold type		C	
		2a + 2b - (switch PF) - silver type		E	
		2a + 2b - (switch PF) - gold type		H	
		3a + 3b - (switch PF) - silver type		K	
		3a + 3b - (switch PF) - gold type		M	
		4a + 4b - (switch PF) - silver type		O	
		4a + 4b - (switch PF) - gold type		P	
		6a + 6b - (switch PF) - silver type		U	
		6a + 6b - (switch PF) - gold type		X	
19	PCC18	(No PCC18) Not applicable	Z		
		1a + 1b - (switch PF) - silver type		1	
		1a + 1b - (switch PF) - gold type		2	
		2a + 2b - (switch PF) - silver type		3	
		2a + 2b - (switch PF) - gold type		4	
20	Installation configuration	Horizontal & Vertical ⁽³⁾	V		V
21	Application type	(Direct Current) DC	D		
		(Alternating Current) AC		A	
22	Opening BMS arc chute	Arc chute lever	A		A

⁽¹⁾ For DC and AC voltage up to 60 Hz frequency. For higher frequency, please contact Sécheron •

⁽²⁾ For the available control voltage in function of the BMS configuration, refer to table page 8. Please note that BMS is delivered with low voltage surge protection •

⁽³⁾ PCC18 is valid for horizontal mounting only. •



Sécheron SA
 Rue du Pré-Bouvier 25
 1242 Satigny - Geneva
 CH-Switzerland

www.secheron.com
 Tel: +41 22 739 41 11
 Fax: +41 22 739 48 11
 ess@secheron.com

Signature:

Name:

Place and date: