

PANTOGRAPH

Type **SPL**

RAIL VEHICLES



GENERAL INFORMATION

SPL pantograph is the ideal solution for manufacturers and operators of tramways and light rail vehicles, looking for an efficient and reliable current collecting device.

With its wide working range (600 – 3,880 mm above roof) and record flatness (400 mm above roof), Sécheron **SPL** pantograph achieves high performances with constrained weight and great stiffness of design.

Its unique panhead suspension system offers **SPL** pantograph an excellent dynamic behaviour, with

great benefits to the contact reliability between the pantograph and overhead lines, as well as to the carbon strips life time. **SPL** are thoroughly tested and surpass standard requirements, making them fully compliant with EN 50126-2/IEC 60494-2 and EN/IEC 61373.

In commercial operation on different tramway networks throughout Europe, **SPL** pantograph has demonstrated its robustness and reliability in different operational and climatic conditions.

APPLICATIONS

SAFETY FUNCTIONS

- ① Pantograph
- ② Selector and earthing
- ③ DC surge arrester
- ④ DC circuit breaker
- ⑤ line breaker box

SPL
SED

UR
SLBB09/18

SWITCHING FUNCTIONS

- ① Line contactor
- ② Charging contactor
- ③ Power contactor module
- ④ Motor isolating contactor

BMS, SEC
PCC, HS
PCM
BMS

MEASUREMENT FUNCTIONS

- ① Current sensor
- ② Voltage sensor

Tramway and LRV vehicles

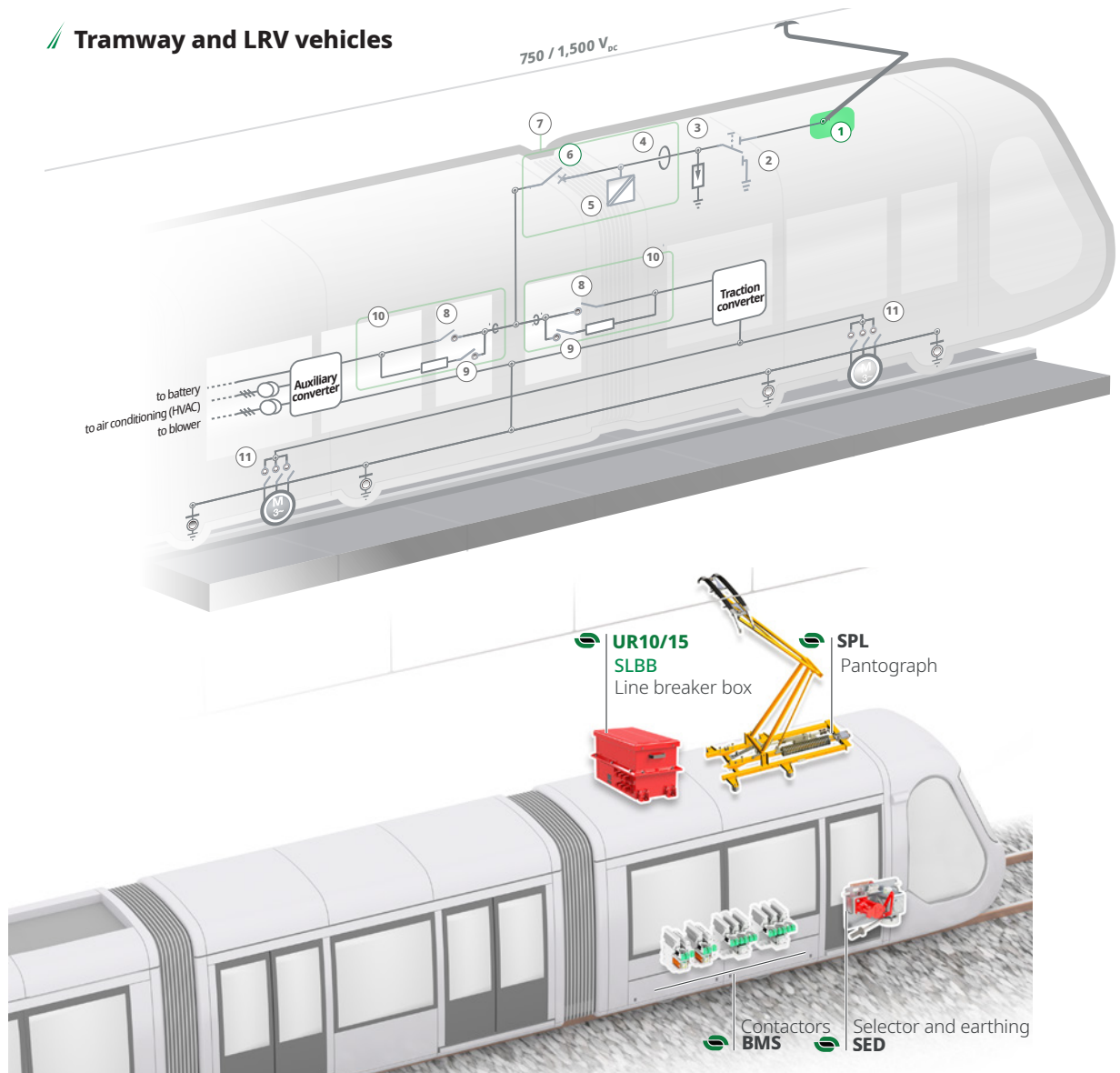

PRODUCT DESCRIPTION

A simple design, made of 4 main elements, guarantees the pantograph reliable operation for operators:

1. The base frame made of a steel welded lightweight profile, enables fixing the pantograph on the vehicle through four insulators. The frame houses all of the other parts (lower and upper arms assembly, damper linear actuator, high and low-voltage electrical interfaces).
2. The lower and upper arms are made of welded thin steel tubes, housing insulated maintenance free bearings. Two unstrained stainless steel rods insure the rigidity. Flexible braids allow safe electrical connections.
3. The panhead, installed on a leaf spring suspension system, is designed to allow free movements in all necessary directions to always guarantee the electrical continuity between the contact strips and the overhead line.
4. The drive unit combines the linear actuator with the main spring to operate the pantograph.

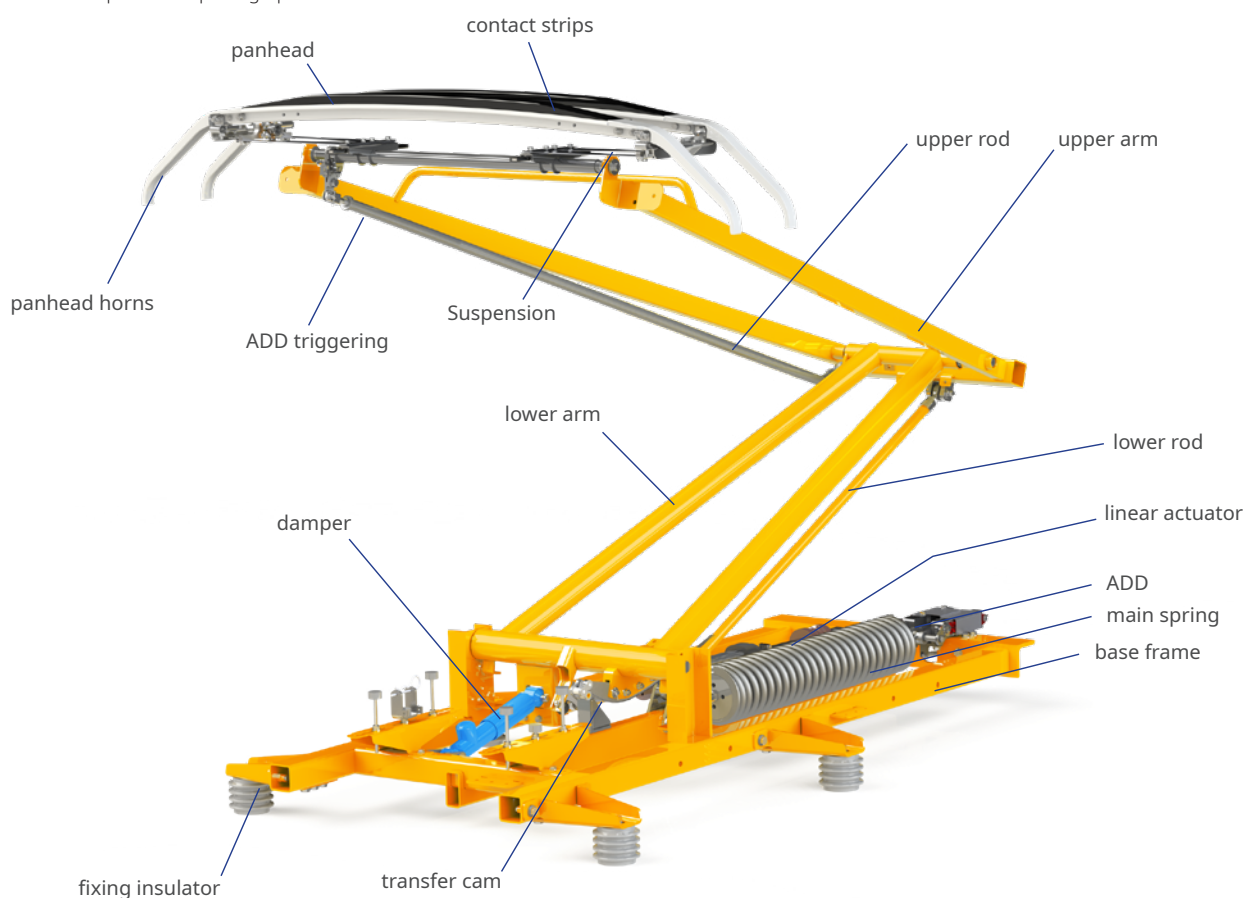

MAIN BENEFITS

- ✓ Unique panhead suspension system offering excellent dynamic performance.
- ✓ Electric raising & lowering.
- ✓ Very compact design – allows to use customizations to match roof fixation points for retrofit projects.
- ✓ In-house key technologies (high-voltage, FEM & Multibody simulations, welding, dynamic test-bench, material & surface treatment, ...).
- ✓ Extensive factory testing for a high reliability in service.
- ✓ Automatic Dropping Device to limit damages due to abnormal shocks on panhead.
- ✓ Unloaded spring mechanism when not operated (in option)
- ✓ Very low maintenance requirements.
- ✓ Worldwide service point network.

DATA FOR PRODUCT SELECTION

	Symbol	Unit	SPL26	SPL30	SPL35
MAIN HIGH VOLTAGE CIRCUIT					
Mechanical characteristics					
Maximal running speed	V_{MAX}	[km/h]	80 (100 in option)	80 (100 in option)	80 (100 in option)
Static contact force	F_{st}	[N]	60 - 110	60 - 110	60 - 110
Maximum weight (without insulators)		[kg]	158 ±5	170 ±5	200 ±5
Main high voltage circuit					
Nominal voltage of the traction system	U_n	[V _{DC}]	600; 750; 1,500	600; 750; 1,500	600; 750; 1,500
Highest permanent voltage	U_{max1}	[V _{DC}]	1,800	1,800	1,800
Rated insulation voltage (HV parts against LV parts)	U_{Nm}	[V _{DC}]	2,300	2,300	2,300
Rated impulse voltage	U_{Ni}	[kV]	18	18	18
Rated operational current fo standstill	I_{es}	[A]	≤ 200	≤ 200	≤ 200
Rated operational current fo running ⁽¹⁾	I_{er}	[A]	≤1,500	≤1,500	≤1,500
Overload capacity for running	I_{adm}	[A]	≤ 2,000	≤ 2,000	≤ 2,000
Overtoltage category			OV4	OV4	OV4
⁽¹⁾ at T _{amb} = 40°C for 10 s.					
LOW VOLTAGE AUXILIARY CIRCUIT					
Control circuit					
Type of the actuator				Electric	
Nominal voltage	U_n	[V _{DC}]		24	
Supply voltage limits ⁽²⁾				[0.7 - 1.25] Un	
Nominal raising power ⁽³⁾	P_r	[W]/[s]		260/20	
Holding nominal power ⁽³⁾	P_h	[W]		0	
Nominal lowering power ⁽³⁾	P_l	[W]/[s]		260/20	
Mechanical raising time ⁽⁴⁾	t_r	[s]		≤ 10	
Mechanical lowering time ⁽⁴⁾	t_l	[s]		≤ 10	
Rated power frequency withstand voltage - control circuit-earth	U_a	[V]/[Hz]/[s]		750/50/10	
⁽²⁾ at -25° C < Ta < +40°C. • ⁽³⁾ At 20°C • ⁽⁴⁾ Typical at U _n and T _{amb} = 20°C					
Auxiliary switches of actuator					
Auxiliary contacts	N			2	
Type				Changeover (CO)	
- Let-through current ⁽⁵⁾		[mA]		150	
- Switching power		[W]		3.6	
Mechanical durability	n			10 ⁶	
Low voltage interface					
Type of connection				1 connector Harting HAN 16E	
⁽⁵⁾ at 24 V _{DC}					
OPERATING CONDITIONS					
Working ambient temperature outdoors	T_{amb}	[°C]		-25°C to +65°C	
Altitude	h			≤ 2,000	
Humidity at 40°C				≤ 95%	
Shocks and mechanical vibrations (according to IEC61373:2010)				Category 1 Class A	
Pollution degree				PD4	
MOUNTING					
Installation				Outdoor	
Applications				Rolling stock, on the vehicle roof	
Monting position				Horizontal	
Fixation				On the roof frame or on the roof fixing supports	
HV Electrical connections				Cu cables or bus-bars	

PRODUCT INTEGRATION

MAIN DIMENSIONS

All dimensions and characteristics in this brochure are valid for standard tramway and light rail vehicles pantographs.

Shall your vehicle-pantograph interfaces be different, please contact Sécheron.

/// SPL26 / SPL30 / SPL35

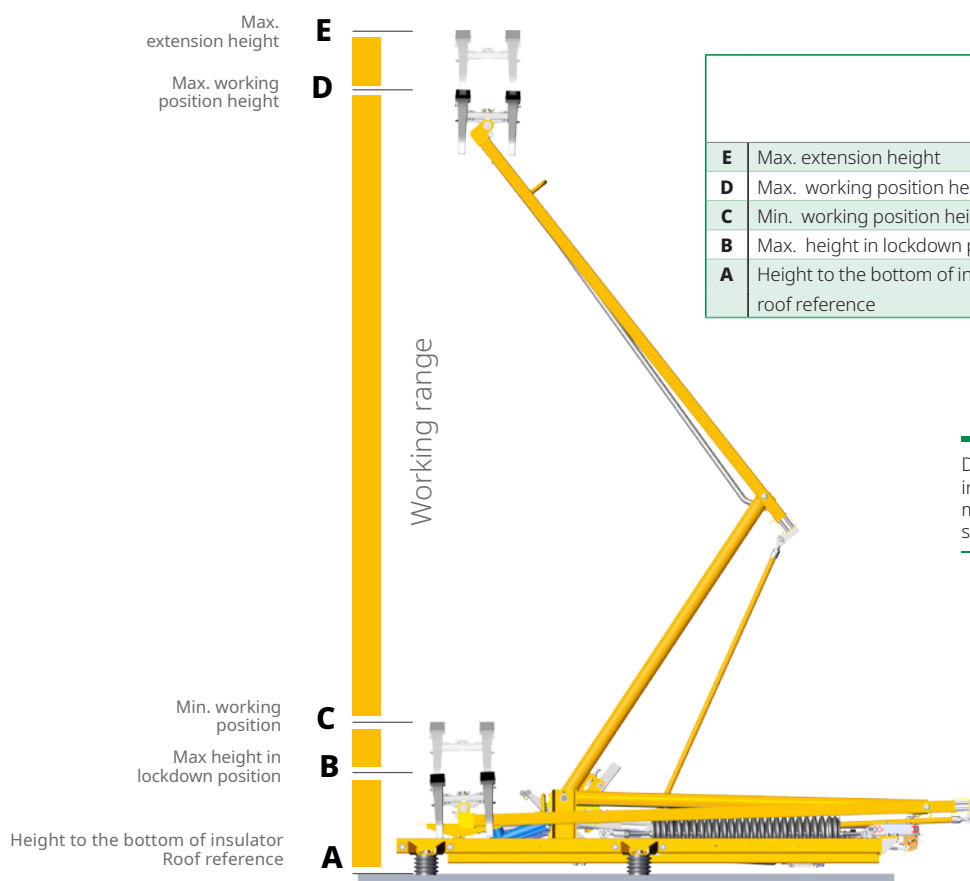

		Working range [mm]		
		SPL26	SPL30	SPL35
E	Max. extension height	3,050	3,500	4,145
D	Max. working position height	3,000	3,400	3,945
C	Min. working position height	600	600	630
B	Max. height in lockdown position	400	400	430
A	Height to the bottom of insulator roof reference	0	0	0

Dimensions without tolerances are indicative. All dimensions are in mm. The maximum allowed flatness deviation of the support frame is 0.5 mm.

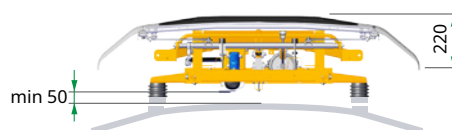
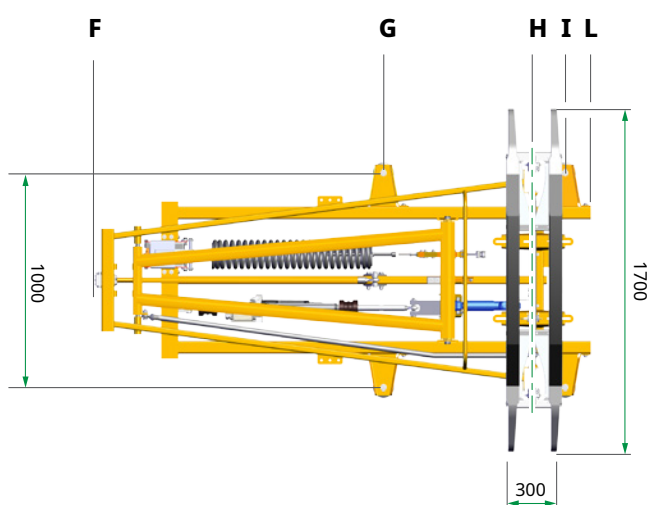

		Main dimensions [mm]		
		SPL26	SPL30	SPL35
F	Front side upper arm	0	0	0
G	Front feet	1,349	1,657	1,695
H	Panhead pivot point	2,049	2,357	2,632
I	Rear feet	2,199	2,507	2,545
L	Rear side frame	2,319	2,627	2,815

CONTROL AND WIRING

TYPICAL SPL PANTOGRAPH CONTROL DIAGRAM

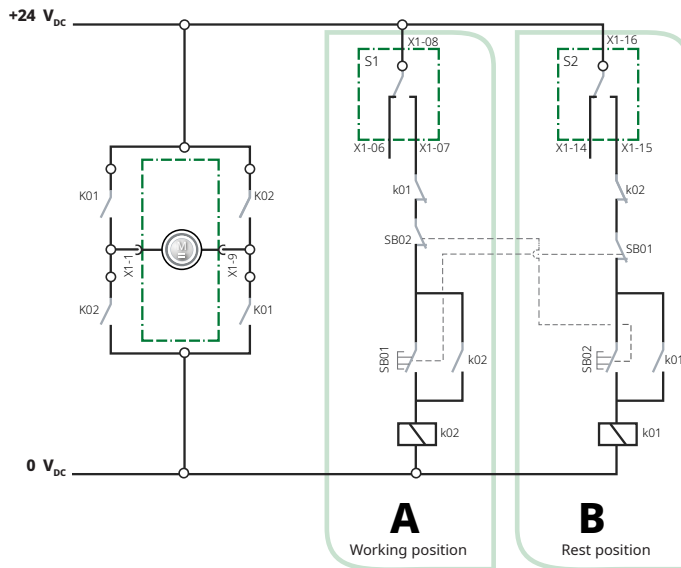

Legend

-  Sécheron scope (Pantograph)
- A** Diagram of the working position
- B** Diagram of the rest position
- K01, K02 Relays
- SB01 Push button to raise the pantograph
- SB02 Push button to lower the pantograph

LOW VOLTAGE CONNECTOR WIRING DIAGRAM

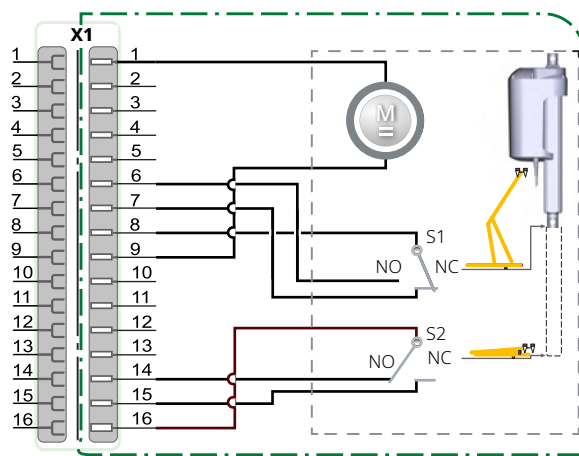

Legend

- X1**: pantograph Harting HAN16B connector 16 poles
- S1**: pantograph position detection switch (pantograph in raised position)
- S2**: pantograph position detection switch (pantograph in low position)

FUNCTIONING DIAGRAM

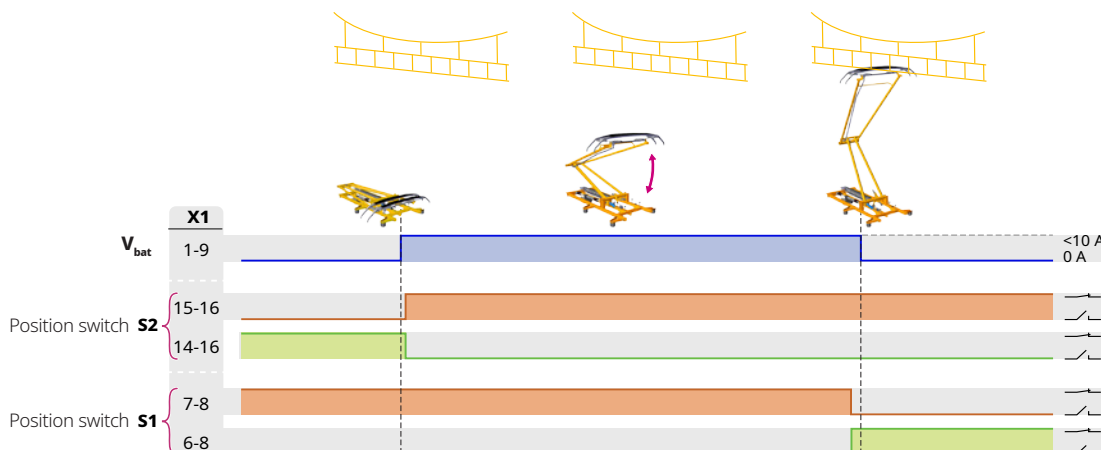

OPTIONS (SUBJECT TO ADDITIONAL COSTS)

MANUAL OPERATIONS DEVICE (MOD)

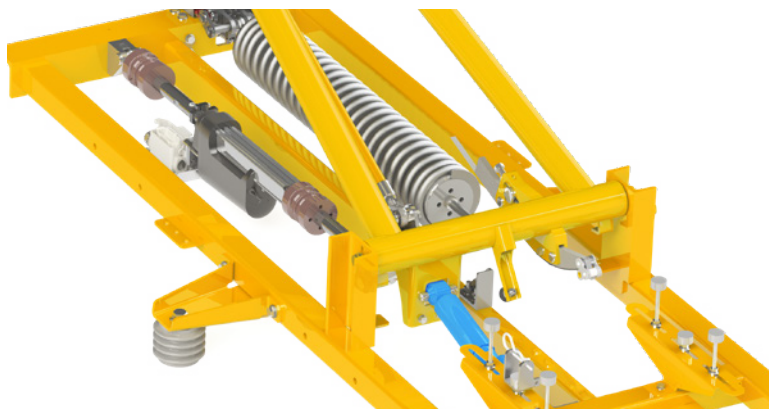

Connection to linear actuator

Would the auxiliary power supply be unavailable, the pantograph can be manually operated through a flexible shaft linked to the linear actuator and accessible from inside the vehicle.

AUTOMATIC DROPPING DEVICE (ADD)



Trigger device (panhead)

To limit damages caused by abnormal shocks applied to the pantograph's panhead during operation, an Automatic Dropping Device can be mounted on the pantograph for a fast-drop action.

MAIN FEATURES

- Mechanical ADD device for panhead disconnection from overhead line in case of heavy shock
- Fast panhead disconnection, less than 1 sec.
- Fast Pantograph lowering, around 3 sec.
- ADD activation in both running directions

MAIN BENEFITS

- ✓ Protect and prevents consequential damages on the overhead line
- ✓ Limits damages on the pantograph

DESIGNATION CODE FOR ORDERING

- Be sure to establish the designation code from the latest version of our brochure by downloading it from the website: www.secheron.com.
- For technical reasons some variants and options indicated in the designation code might not be combined, therefore validate your configuration with Sécheron before ordering.
- For other configurations not described in the brochure, please contact Sécheron.

DESIGNATION CODE

Line	Description		Designation		Customer's choice
			Standard	Options	
10	Product type	SPL	SPL	SPL	SPL
11	Max. working extension above roof	(Only loaded spring available) SPL35: 3,880 mm SPL30: 3,300 mm SPL26: 2,900 mm	•		
12	Rated operational voltage	900 V _{DC} 1,800 V _{DC}	•		
13	Maximum running current	1,000 A 1,500 A	•	•	
14	Maximum standstill current	100 A 150 A 200 A Please specify optional maximum standstill current below	•	•	
15	High voltage interface	3 × M10	•		
16	HV interface Location	Below Panhead/Both sides	•		X
17	Control voltage (electric drive)	24 V _{DC}	•		
18	Color	Dark grey (RAL 7011) Yellow (RAL 1003) Red (RAL 3020) Black (RAL 9011) Please specify optional RAL color code below	•	•	
19	Manual operation device (MOD)	No Yes	•	•	
20	- Length of MOD flexible shaft	1.5 m Optional length 2.0 & 2.5 m	•	•	
21	- Spare digit	Not applicable	•		X
22	Automatic dropping device (ADD)	No Yes	•	•	

PANHEAD CHARACTERISTICS

A: total width: _____ mm

B: distance between strips center lines: _____ mm

C: strip width: _____ mm

D: strip length: _____ mm

Horn material Aluminium Insulating material
Strip material Carbon Metal impregnated carbon Copper

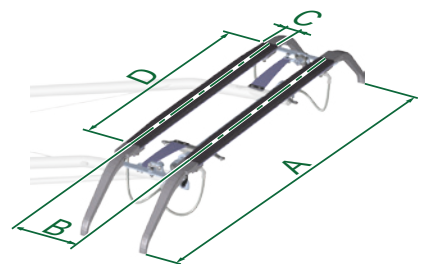

CUSTOMER DATA

Maximum standstill current: _____ A

Length of the MOD flexible shaft: _____ mm ± _____ mm

Color option: RAL _ _ _ _



📍 Sécheron SA
Rue du Pré-Bouvier 25
1242 Satigny - Geneva
CH-Switzerland

www.secheron.com
Tel: +41 22 739 41 11
Fax: +41 22 739 48 11
ess@secheron.com