

# DIODE RECTIFIERS

## EFFICIENT-**REC-D**



# EFFICIENT

## POWER CONVERSION



Using experience accumulated over more than 50 years working in the field of traction power substations, Sécheron has designed the EFFICIENT product category from the ground up to cover all the customer needs for DC supplies.

All EFFICIENT products are built specifically to comply with the most stringent requirements of usability, maintainability and durability in traction power application environments, maximizing the return of investment for our customers. These reliable and field-proven building blocks are also the basis for custom applications upon specific requests.

## GENERAL INFORMATION

### APPLICATIONS

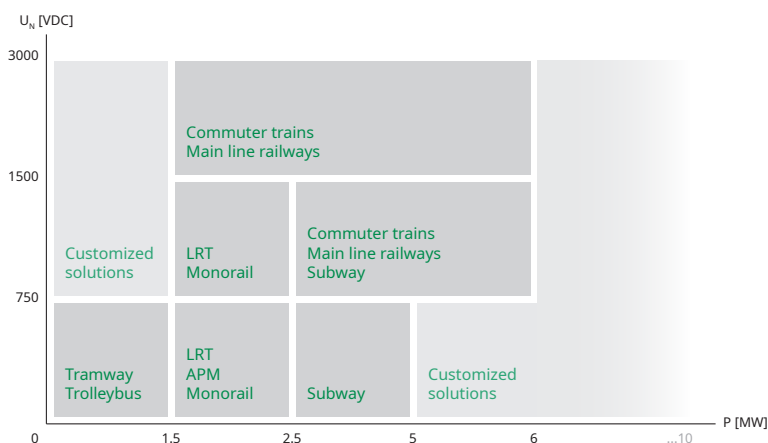

Thanks to its complete range of rated voltages, Sécheron is able to cover all types of traction networks.

With many years of experience in the field, Sécheron is able to propose a reliable and suitable range of diode rectifiers for DC traction power supply. Our natural air cooled rectifiers are equipped with diode blocks with high overload capability and high blocking voltage.

The design of the rectifiers is based on ideally sized and proven semi-conductors (silicon diodes) offering particularly high performances and reliability. All components are fully interchangeable.

Rectifiers are designed in accordance with customers' specifications and with the relevant standards.

## MAIN BENEFITS

- ✓ Compact design
- ✓ Adaptability: Power connection from either the top or the bottom of the cubicle
- ✓ Ease of access for easy maintenance of components
- ✓ Reliable, robust and high quality solution
- ✓ Natural air cooling
- ✓ High efficiency
- ✓ Safe and reliable

# MAIN CHARACTERISTICS

	Unit	Values		
		750 V	1 500 V	3 000 V
<b>Standard rectifier range</b>				
Rated DC voltage	[V]	750	1 500	3 000
Rated current	[A]	Up to 6 000	Up to 4 000	Up to 3 000
Overload	-	Class VI per EN 50328 / IEC 60146 Extra Heavy Traction Service per IEEE 1653.2		
Temperature range (without derating)	[°C]	-5 / +40	-5 / +40	-5 / +40
Maximum altitude (without derating)	[m]	1 000	1 000	1 000
Peak reverse voltage of diode	[V]	2 200	4 500	4 500
Protection degree	-	Up to IP32	Up to IP32	Up to IP32
Width	[mm / in]	800-3 200 / 31.5"-126"	800-3 200 / 31.5"-126"	1 200-2 400 / 47.25"-94.5"
Depth	[mm / in]	1 400 / 55"	1 400 / 55"	1 400 / 55"
Height	[mm / in]	2 200 / 86.5"	2 200 / 86.5"	2 200 / 86.5"

Other ratings, dimensions and overloads upon request.

# STANDARDS

Our rectifiers are fully compliant and type tested according to the following standards:

- **IEC 60146-1-1 (EN 60146-1-1)** | Semiconductor converters – General requirements and line commutated converters - Part 1-1: Specification of basic requirements
- **IEC 60747** | Semiconductor devices
- **IEC 62590 (EN 50328)** | Railway applications – Fixed installations – Electronic power converters for substations
- **IEEE/ANSI C34.2** | Practices and Requirements for Semiconductor Power Rectifiers
- **IEEE 1653.2** | Uncontrolled Traction Power Rectifiers for Substation Applications Up to 1500 V DC Nominal Output



# CONNECTIONS

## // 6-pulse - Up to 1 500 VDC

- Connection n°8 according to IEC 60146-1-2
- Connection n°23 to 26 according to IEEE 1653.2

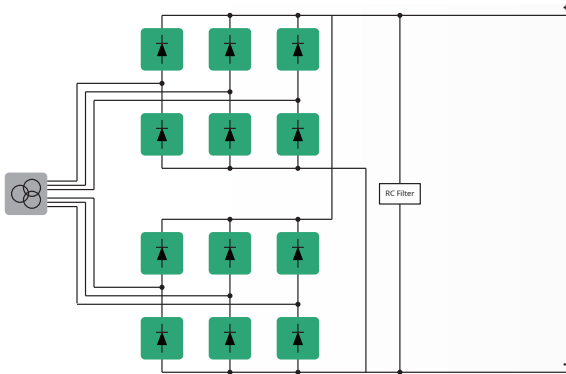
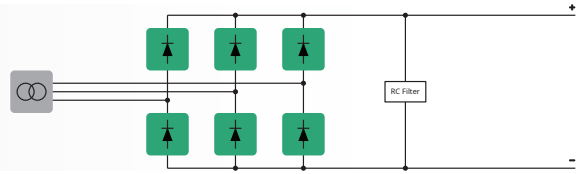

## // 12-pulse parallel, without IPT Up to 1 500 VDC

- Connection n°9 according to IEC 60146-1-2
- Connection n°29 according to IEEE 1653.2

## // 12-pulse parallel, with IPT Up to 1 500 VDC

- Connection n°9 according to IEC 60146-1-2
- Connection n°31 according to IEEE 1653.2

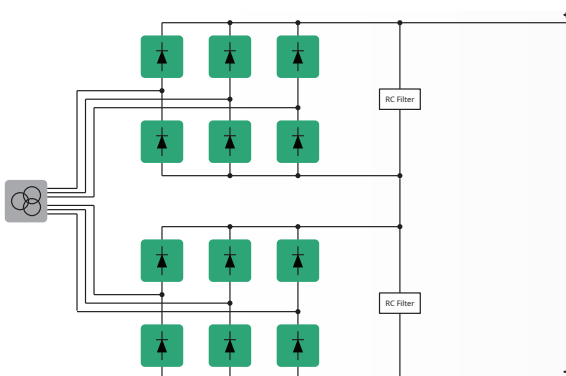
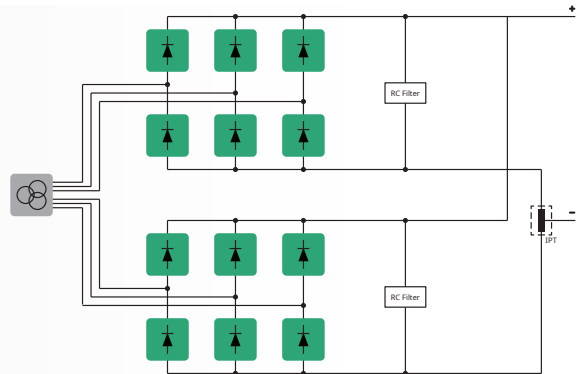

## // 12-pulse series Up to 3 000 VDC

- Connection n°12 according to IEC 60146-1-2
- Connection n°31B according to IEEE 1653.2

## // 24-pulse

Two transformer-rectifier groups each 12 pulses and with adequate phase shift  $\pm 7.5^\circ$  on primary can be provided to achieve 24 pulses rectification.

## // Special connection (upon request)

- Connection n°5 according to IEC 60146-1-2
- Connection n°45 according to IEEE 1653.2

# PROTECTIONS



## OVERVOLTAGE PROTECTION

### Internal overvoltage

During turn-off, the load current of the diode does not stop flowing immediately but continues briefly in reverse direction as reverse recovery current. This peak reverse recovery current causes a voltage peak which is eliminated by an individual snubber circuit mounted in parallel with each diode.

### External overvoltage

Essentially due to lightning strikes, AC circuit breaker operation at no-load or short-circuits, external overvoltage can occur. The rectifier is equipped on the DC side with a RC filter capable of absorbing significant surges.

## SHORT-CIRCUIT PROTECTION & IMMUNITY LEVELS

All traction rectifiers are designed to withstand external short circuit without damage until the MV circuit breaker opens. All immunity levels below are according to EN 50328 standard.

### Fuseless rectifiers (Damage)

Each branch has one diode only and the diodes failure detection is ensured by the reverse current protection (32).

### Rectifiers with fuses (Np) (Tripping)

Composed of several parallel diodes in each branch, the failed diode will be isolated from the circuit by melting the associated fuse, witnessed by the fuses own micro-contact. After melting of the fuse, the rectifier is withdrawn from operation.

### Rectifier in Np+1 configuration (Redundancy)

Additional diode in each branch in order to provide full performance after failure of one diode in each branch.

### Rectifier in Np-1 configuration (Functional)

The rectifier continues providing service with reduced performance after losing up to one diode in each branch; the performance is guaranteed for rated power and some reduced overload.

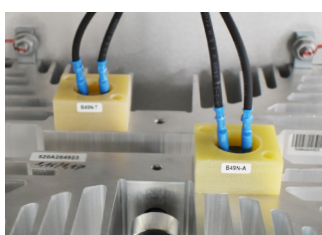

## OVERLOAD PROTECTION

Rectifier diodes are protected against over-temperatures by thermostats mounted on heatsinks (alarm and trip thresholds).

# CUSTOMIZED DESIGN

In order to cover all customer requirements, Sécheron can provide different designs of rectifiers.

## FIXED RECTIFIER

- Compact & robust.



## DRAWOUT RECTIFIER

- Interchangeable & easy maintenance.



## RECTIFIER WITH INSULATING SWITCH

Sécheron also offers a cubicle which integrates both functions of rectifier (up to 1200 kW) and isolating switch (without charge) for special applications for light rail systems (compact solution for tramway and trolley-bus).

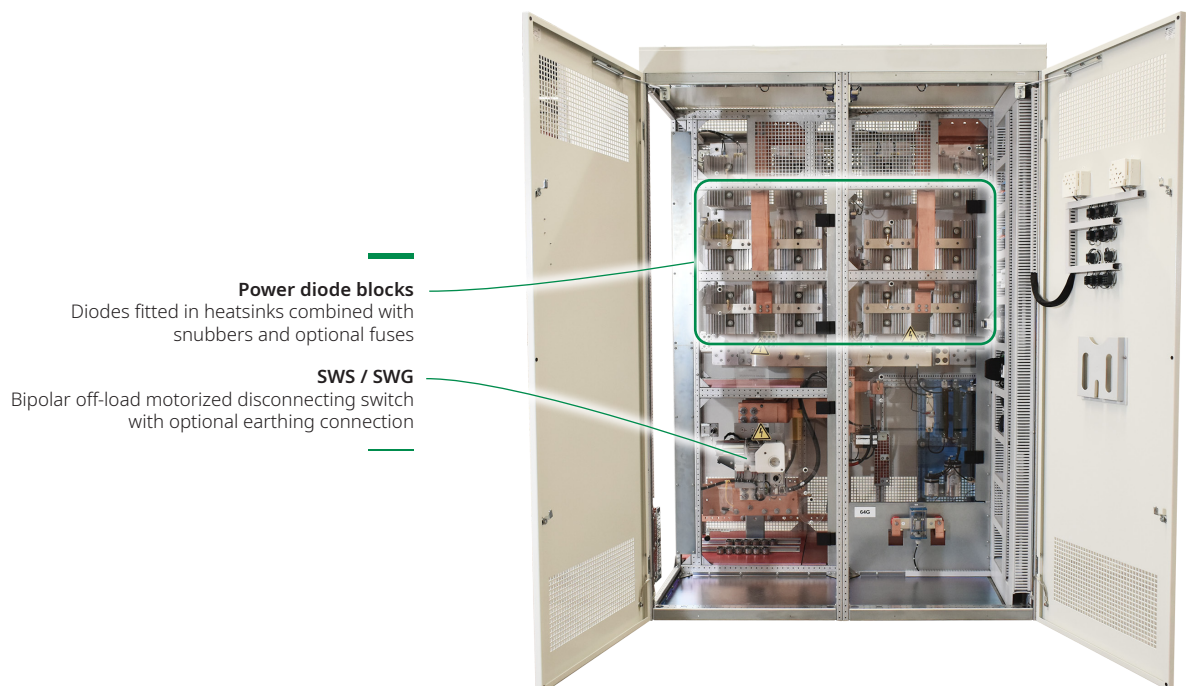

**Power diode blocks**

Diodes fitted in heatsinks combined with snubbers and optional fuses

**SWS / SWG**

Bipolar off-load motorized disconnecting switch with optional earthing connection

# TRANSFORMER-RECTIFIER GROUP

Based on strong experience, Sécheron provides an engineering and consulting support service for traction transformers according to standards IEC 62695 (EN 50329) and IEEE 1653.1:

- Technical specification
- Monitoring during manufacturing process with the supplier
- Assistance during factory acceptance test
- Assistance during combined tests of the complete transformer-rectifier group

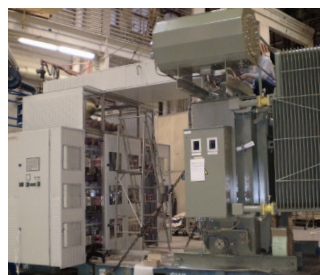

To ensure the compatibility of rectifier and transformer, Sécheron is able to provide the complete transformer-rectifier group.

## RELATED PRODUCTS

### REC-T

#### THYRISTOR CONTROLLED RECTIFIERS

Customer benefits:

- Regulation of the voltage in order to compensate voltage drops of the line
- External DC short-circuit limitation
- Optimization of the functioning in case of double converter (controlled rectifier coupled with inverter)

 Refer to **Brochure REC-T** • SG841750BEN



### BDUCT

#### AC/DC BUS DUCTS

 Refer to **Brochure BDUCT** • SG859912BEN



**Sécheron SA**

Rue du Pré-Bouvier 25  
1242 Satigny - Geneva  
CH-Switzerland

**[www.secheron.com](http://www.secheron.com)**

Tel: +41 22 739 41 11  
Fax: +41 22 739 48 11  
[tps@secheron.com](mailto:tps@secheron.com)

**Copyright © • 2024 • Sécheron SA**

This document is not contractual and contains information corresponding to the level of technology at the date of printing. Sécheron reserves the right to modify and/or improve the product, whose characteristics are described in these documents, as required by new technology at any time. It is the purchaser's responsibility to inform himself, no matter what the circumstances, of the product's maintenance conditions and requirements. Sécheron reserves all rights, especially those arising from our "General Delivery Conditions".